

**EBB**  
**MOMENT LIMITING DEVICE**  
**FOR TRUCK CRANES**

**INSTALLER MANUAL**



Date : 14/06/2005  
Sw. ver. : AV02\_8

# CONTENTS

System description	Page 2
System composition	Page 3
Installation directions	Page 4
User interface description	
main panel	Page 5
remote panel	Page 5
Functions	
emergency stop	Page 6
energy saving	Page 7
hour counter	Page 8
sound warning system	Page 9
moment limiting device (auxiliary functions)	Page 10-12
winch pull limiting device	Page 13-17
rotation control	Page 18, 19
moment limiting device disabling	Page 20
equipment activation (jib, winch, rotor, and bucket)	Page 21
alarms bypass	Page 22
oil filters inspection	Page 23
radio control	Page 24
jack arms control	Page 25
maintenance	Page 26-37
usage statistics	Page 38
black box	Page 39
Display	
Setting a value	Page 40
Menu description and navigation	
main menu	Page 41
check menu	Page 42
inputs menu	Page 43 – 45
outputs menu	Page 46
sensors menu	Page 47
alarm menu	Page 48
service menu	Page 49, 50
setting menu	Page 51, 52
config. menu	Page 53
pressure menu	Page 54
winch menu	Page 55
boom and jib angle menu	Page 56
time setting menu	Page 57
Calibration	
parameters list and description	Page 58 – 61
basic calibration from panel	Page 62
Diagnostics	
inputs list and description	Page 63
outputs list and description	Page 64
Alarms	Page 65, 66
Warnings	Page 67
Problem solving	Page 68
List of EBB sheet resources	Page 69

---

## SYSTEM DESCRIPTION

The system is a moment limiting device for truck cranes based upon the reading of pressures inside the lifting jacks. Pressures are compared in real time with the settable limit thresholds, which represent the crane maximum lifting capacity.

The system includes a series of functions and controls listed below:

- management of allowed movements in case of activation of the moment limiting device in relation to the boom position;
- management of auxiliary functions: Jib, Winch, Rotor, and Bucket and related blocks or movement consensuses;
- rotation management;
- failures and malfunctioning self-diagnostics;
- black box and usage statistics;
- management of scheduled maintenance operations;

The equipment is fitted with a main panel with a 2 lines x 16 characters display displaying pressures, usage percentages, operating and alarm messages, and some programming and diagnostics menus. 8 LEDs are in place for important operating signals which must be easily seen by the operator.

The 9 keys can be used to enable some operating functions, e.g. horn activation, limiting device disabling (RESET), etc., and for menu management and navigation.

The main functions are located on the other side of the truck and can be managed by means of a second panel.

The equipment is also connected to a Radio control (optional), so as to optimise and preserve the correct operation of the entire crane.

The software installed on the equipment is designed to achieve the best possible performances while ensuring the utmost safety.

## SYSTEM COMPOSITION

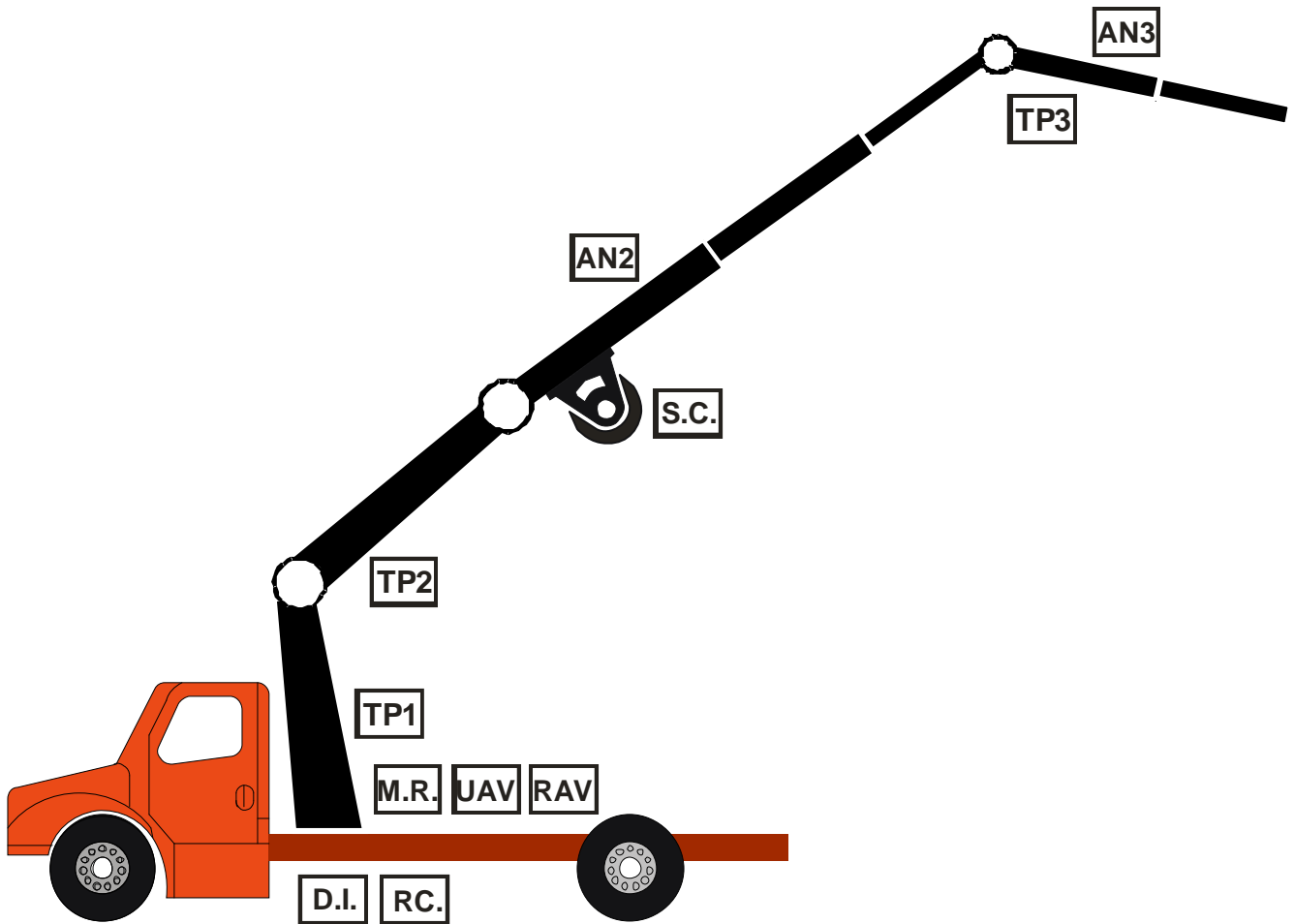

UAV	Central unit
RAV	Remote unit for second control station
D.I.	Hydraulic distributor
RC.	Radio control
M.R.	Micro switches for rotation control
TP1	Primary Boom pressure transducer
TP2	Secondary Boom pressure transducer
TP3	Jib Boom pressure transducer
AN2	Secondary Boom angular sensor
AN3	Jib Boom angular sensor
S.C.	Winch load sensor

## INSTALLATION DIRECTIONS

The EEB system must be supplied in one of the following ways, to ensure its correct operation and to prevent the truck battery from running down:

1. Through power takeoff with power auxiliary relay.
2. Through truck ignition key.
3. Through external general switch or key.

Whenever possible, avoid direct connection to the vehicle batteries.

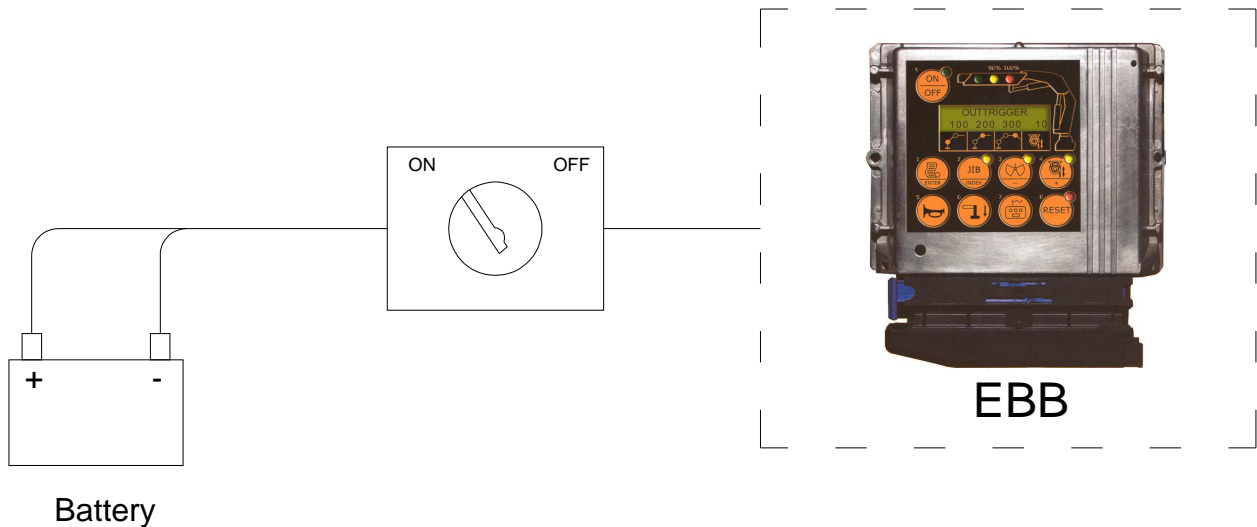

### IMPORTANT:

Do not carry out any welding operation on the vehicle when the EEB is connected, to prevent damaging all system electronic components.

**ALL WELDING OPERATIONS SHALL BE CARRIED OUT WHEN THE EEB POWER SUPPLY CABLE IS DISCONNECTED.**

## USER INTERFACE – MAIN PANEL

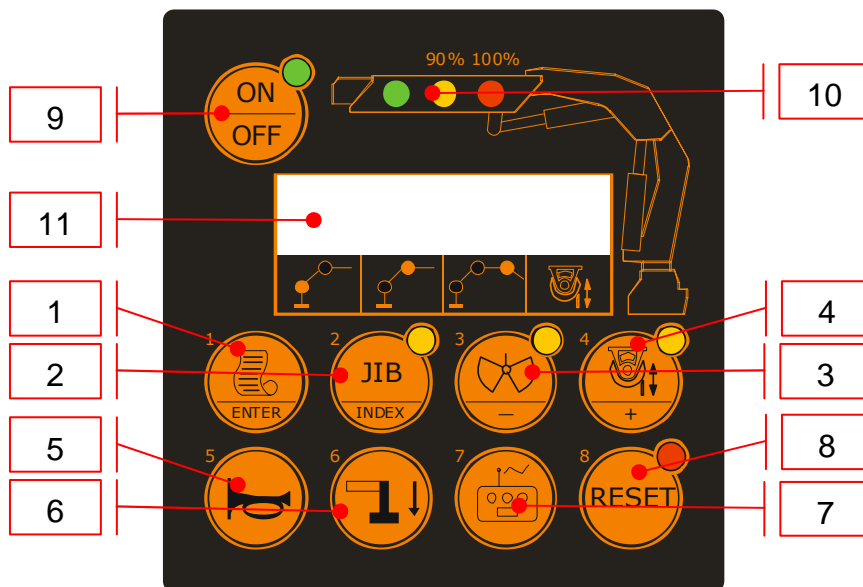

1	Pressure display in bar, dPsi and percentages or date and hour (Menu: Enter / Confirm)
2	Enable / Disable JIB usage (Menu: Select / Exit)
3	Enable / Disable BUCKET / ROTOR usage (Menu: Page down / decrease value)
4	Enable / Disable WINCH usage (Menu: Page up / increase value)
5	Enable / Disable horn
6	JACK ARMS mode activation
7	RADIO / MANUAL mode selection
8	Limiting device disabling / Alarms reset
9	Power on / Stand-by
10	Led bar showing crane usage percentage
11	Display for Operating Messages, Pressures, and Menus

## USER INTERFACE – REMOTE PANEL

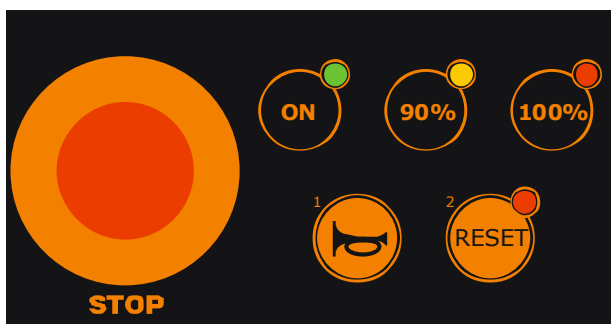

1	Enable / Disable horn
2	Limiting device disabling / Alarms reset
3	Emergency knob
4	Led bar showing crane usage percentage

## FUNCTIONS

### EMERGENCY STOP

When the emergency stop knob is pressed power supply is electrically and mechanically cut to all system outputs, including the one controlling the distributor exhaust solenoid, thus stopping the crane. When the knob is released the equipment checks that all distributor levers have gone back to 'neutral' before re-enabling crane operation. When the main emergency knob or the secondary panel knob are pressed, this is shown on the display as follows:

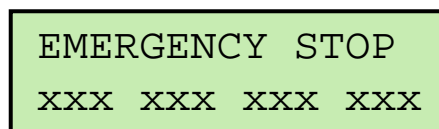

The same is also shown on the secondary panel, where the 90 and 100% LEDs flash.

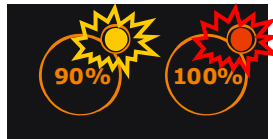

## ENERGY SAVING

The standby function is an energy saving mode: all outputs, LEDs, and the display backlighting are off.

The standby mode can be activated manually by pressing the ON-OFF key. Alternatively, it activates automatically after a time span set during calibration.

The equipment can be reactivated by pressing the ON-OFF key.

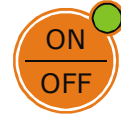

The standby mode is indicated on the display and by the flashing ON/OFF key LED.

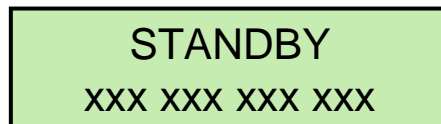

The mode is shown on the remote panel by the flashing ON LED.



## HOUR COUNTER

The equipment is fitted with a clock and an internal calendar and shows the number of hours the limiting device has been operating on the main panel display.

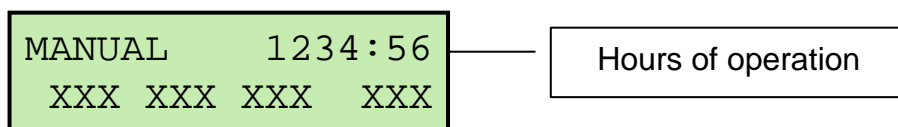

This figure is constantly updated: the counter will only stop when it is in the standby mode and when the system is off.

---

## SOUND WARNING SYSTEM

The system can be connected to an external sound warning system (e.g. Horn).

The system activates automatically and makes the horn sound intermittently when crane usage exceeds 90% and continually when 100% is exceeded.

The sound warning system can also be activated manually by means of a dedicated key located both on the main panel and on the remote panel.



## MOMENT LIMITING DEVICE

The moment limiting device operation is based upon the real-time reading of the pressures measured, by means of transducers, inside the crane jacks. The primary jack pressure transducer is always present, just like the Jib jack transducer -if the Jib is installed on the crane-, while the secondary boom jack transducer is installed only when the crane frame needs to be further protected.

The recorded pressure indicates the crane's 'moment' (the force which loads and tends to overturn the crane); this force should never exceed a specific limit, otherwise the crane could overturn or be damaged. The system constantly checks that the pressure does not exceed the pre-set limit; when the maximum limit is reached, the crane will be stopped and only those manoeuvres reducing the overturning force will be possible.

The highest crane usage percentage among the recorded ones is indicated by three LEDs located both on the main panel and on the secondary panel, which show whether operation is safe, whether it has exceeded 90% of the maximum limit or whether it has reached 100%.

The main panel shows in detail the value of the usage percentages for each jack; alternatively, it is possible to display individual pressures in BAR or in PSI (USA pressure measurement unit) or the current date and hour.

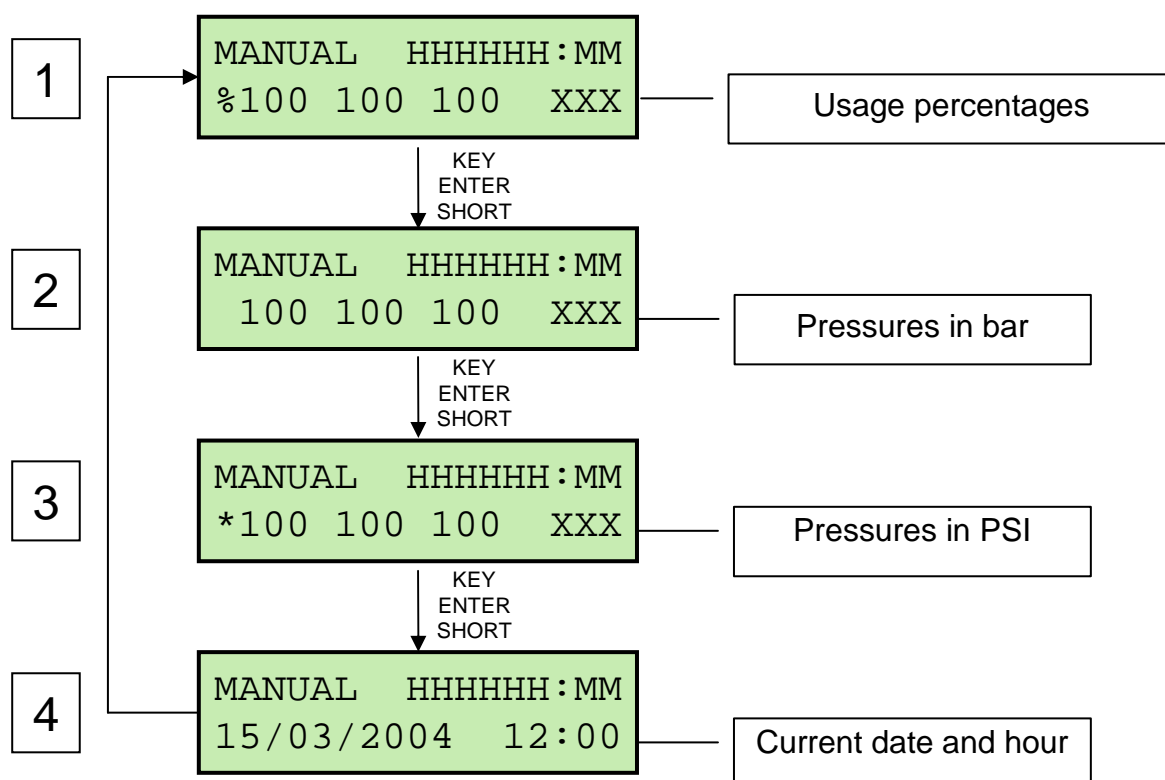

## MOMENT LIMITING DEVICE

The system is equipped with angular sensors detecting the crane boom position. This information allows the system to know which manoeuvres reduce the crane load, and are therefore allowed, and which manoeuvres, conversely, increase it and are, therefore, not allowed.

Here below the crane is shown in its various positions. For each position the movements allowed and not allowed by the system are also shown.

### Movements allowed in Primary Boom and/or Secondary Boom block conditions

Allowed manoeuvre ←   Non-allowed manoeuvre

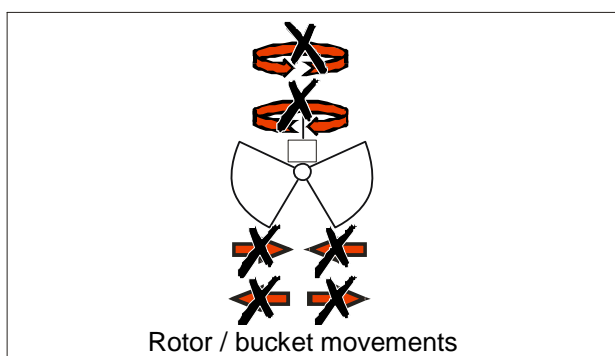
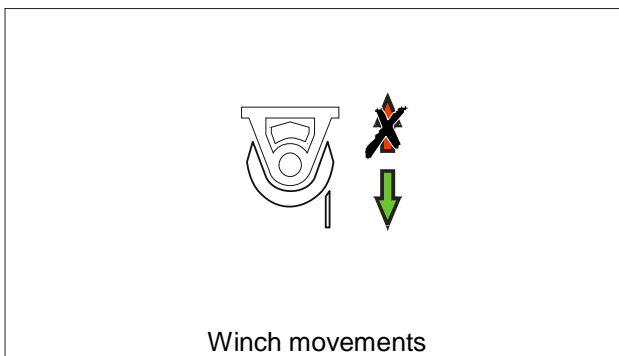
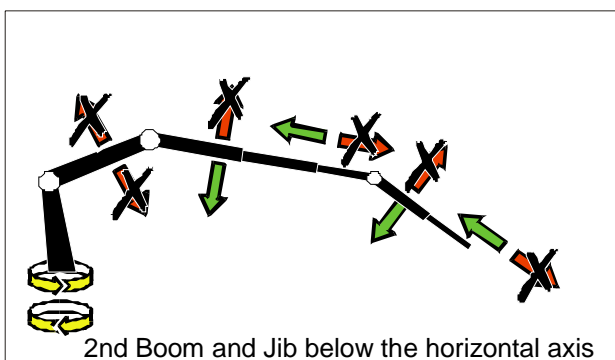
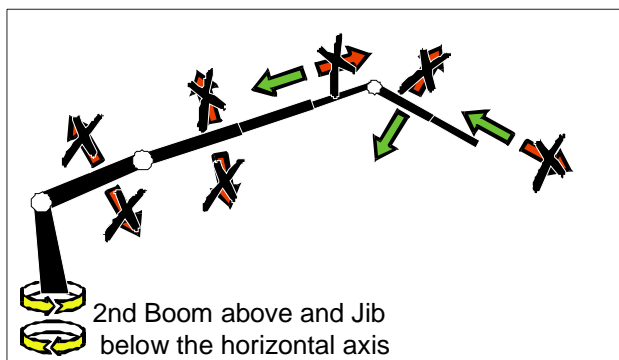
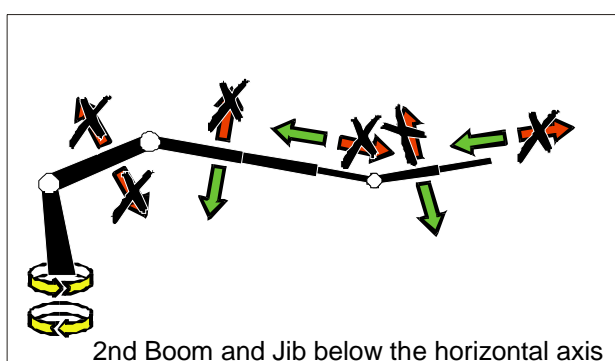
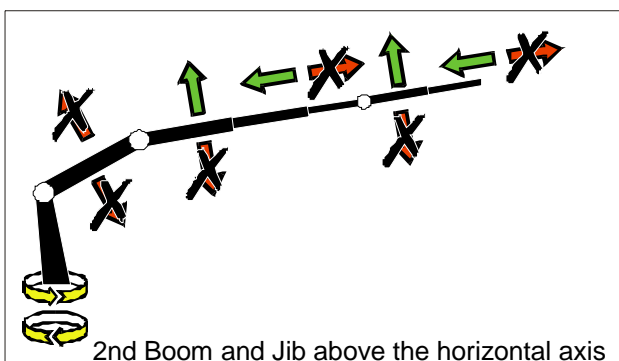

## MOMENT LIMITING DEVICE

### Movements allowed in Jib Boom block conditions

Allowed manoeuvre ← Non-allowed manoeuvre

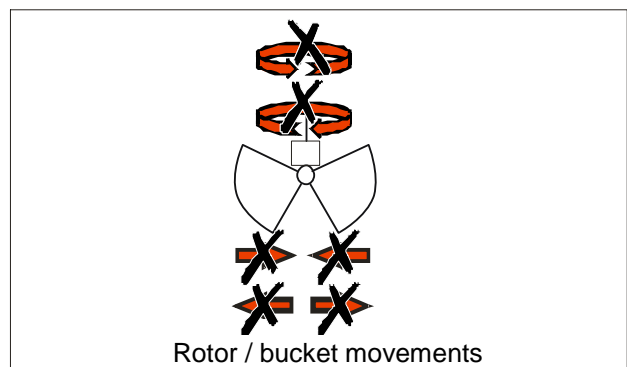
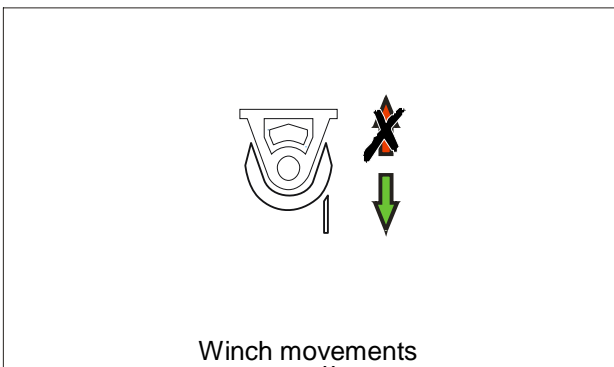
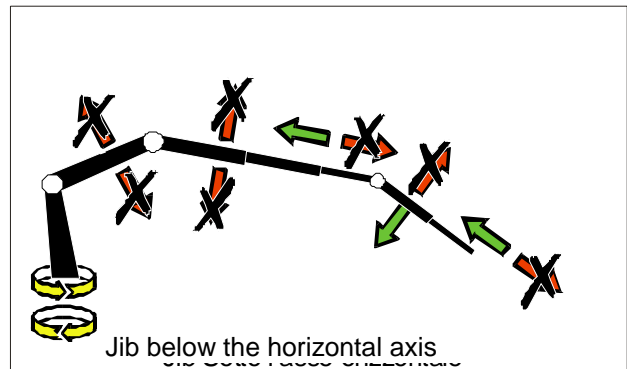
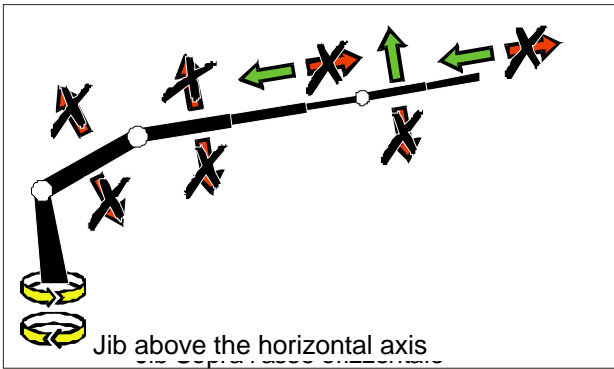

### Auxiliary Functions

The system may detect that the crane has reached maximum usage even when it is not loaded. This condition occurs when a jack bottoms out because induced pressure in the jack has exceeded the maximum limit. The system can detect this condition and allows for boom descent -even when this movement is not allowed – for a very short time, to eliminate such condition automatically.

Allowed manoeuvre ←

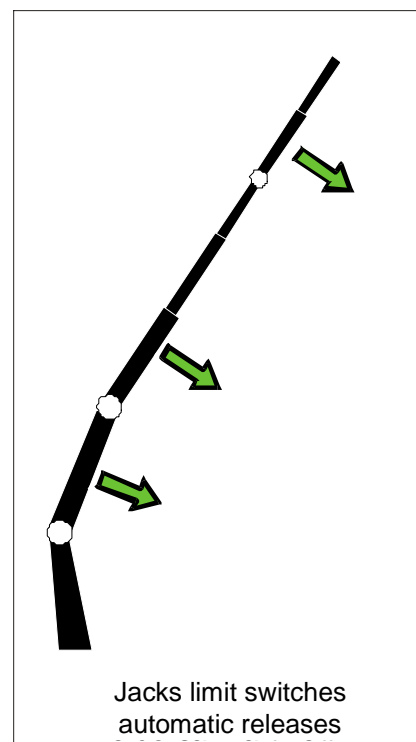

## WINCH PULL LIMITING DEVICE

The crane can be equipped with a winch. In this case the system is fitted with a device capable of controlling the pull applied on the rope to prevent overloading the winch and the rope itself.

Through this device, a load sensor or an extensometer applied to the winch and the sensor's signal amplifier, the limiting device can assess – as in the case of pressures – whether the winch is being used safely, at 90% or at 100% of its capacity.

If the usage percentage is higher than the pressures percentage, it is shown by the three LEDs on the main panel and the secondary panel, indicating the crane usage percentage.



The main panel display always shows the winch usage percentage.

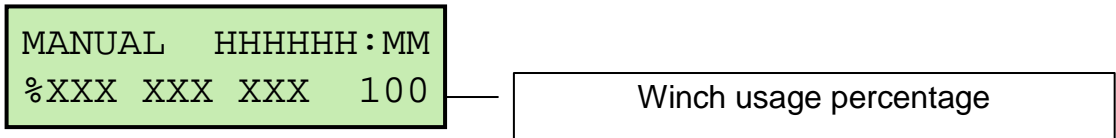

## WINCH PULL LIMITING DEVICE

In the event of a winch overload, the crane will be blocked. In this case too only those manoeuvres reducing load on the frame will be allowed, as shown in the following figures:

### Movements allowed in Winch block conditions

Allowed manoeuvre ←   Non-allowed manoeuvre

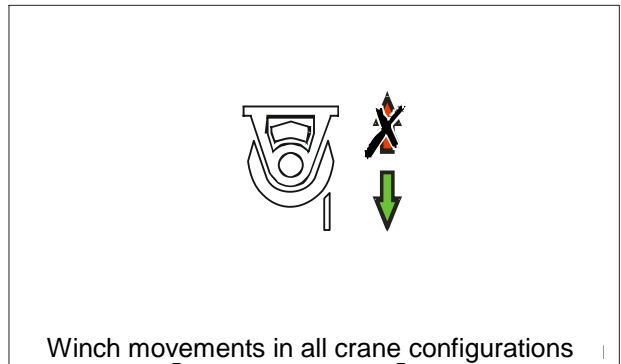
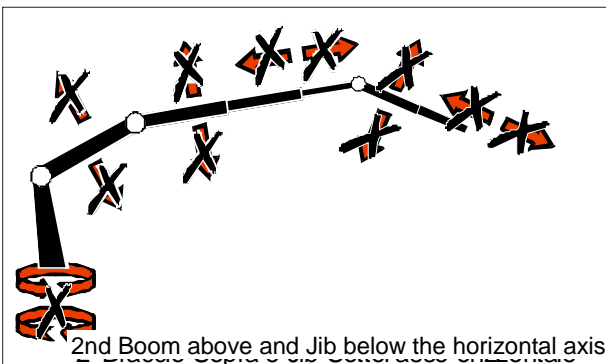
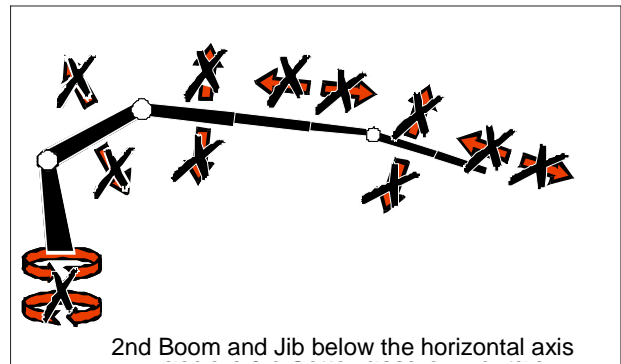
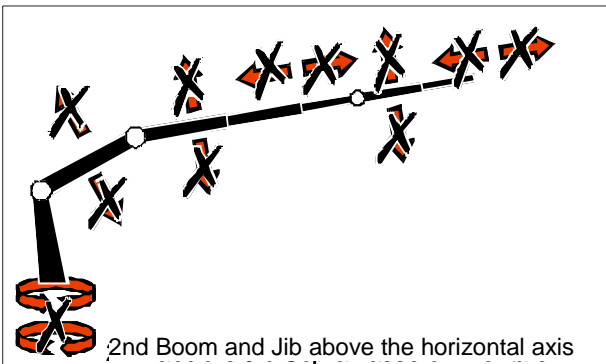

## WINCH PULL LIMITING DEVICE

The winch is equipped with a limit switch which indicates that the rope is completely uncoiled. In this case the following message will appear on the display:

WINCH STOP DOWN  
%XXX XXX XXX XXX

### Movements allowed in Winch end-of-descent conditions

Allowed manoeuvre Non-allowed manoeuvre

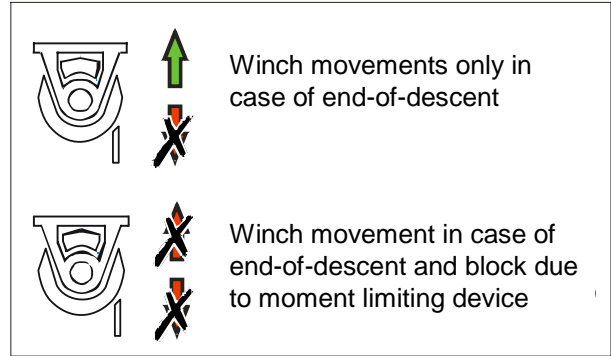
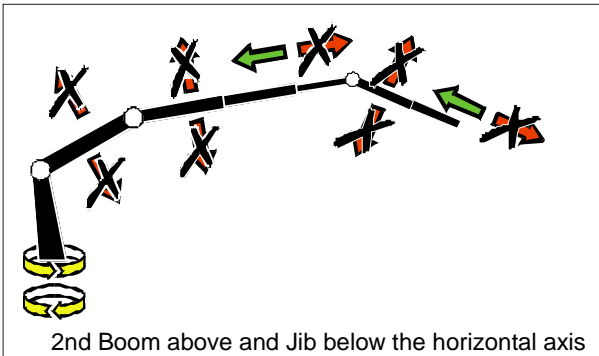
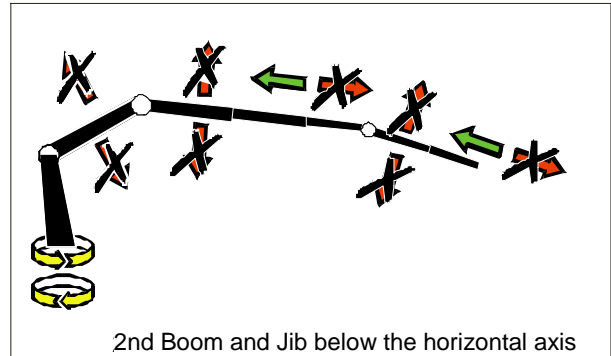
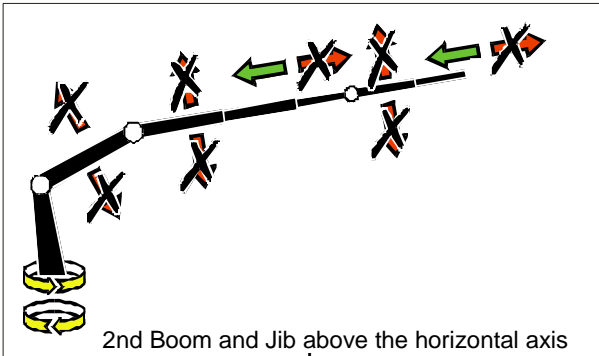

## WINCH PULL LIMITING DEVICE

In some cases the crane may be equipped with a winch rope ascent limit switch, which indicates when the block has bottomed out against the tip of the boom; this condition is shown on the display as follows:

WINCH STOP DOWN  
 %XXX XXX XXX XXX

### Movimientos permitidos en condiciones de fin de carrera bajada cabrestante

Allowed manoeuvre ← → Non-allowed manoeuvre

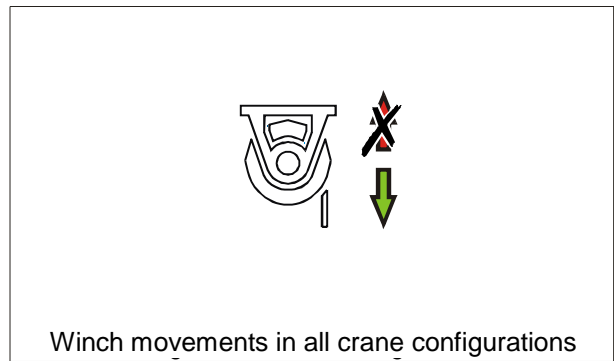
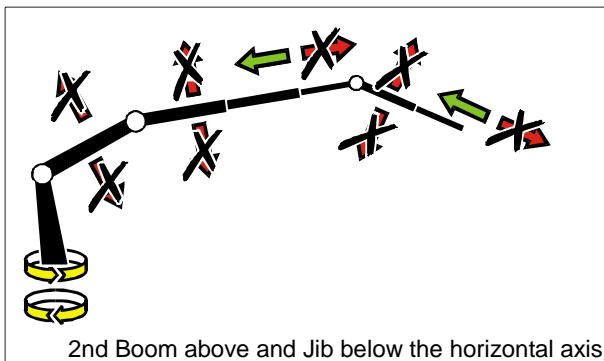
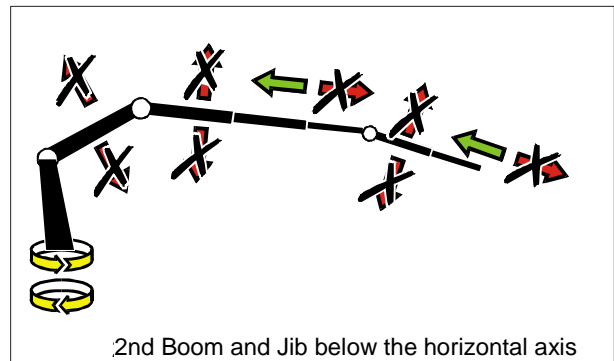
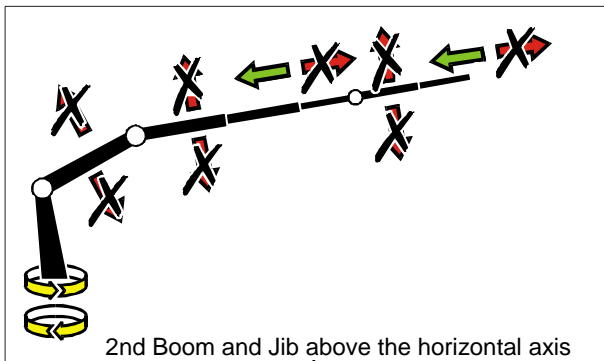

**SPECIAL VERIFICATIONS**

The crane can be equipped with winches sized for that specific type of crane, type 1, or with winches having a capacity higher than the one of the crane, type 2.

If type-1 winches are used, the winch maximum pull will be the same in all crane positions.

If type-2 winches are used, the winch maximum pull depends on the crane position. More specifically, depending on the angle of the secondary boom or on the Jib angle, the maximum allowable pull will be reduced to safeguard the crane frame.

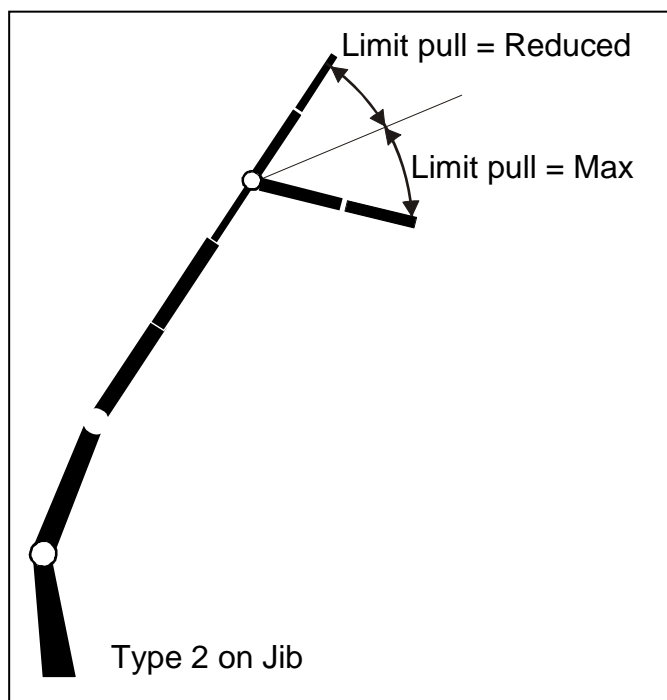
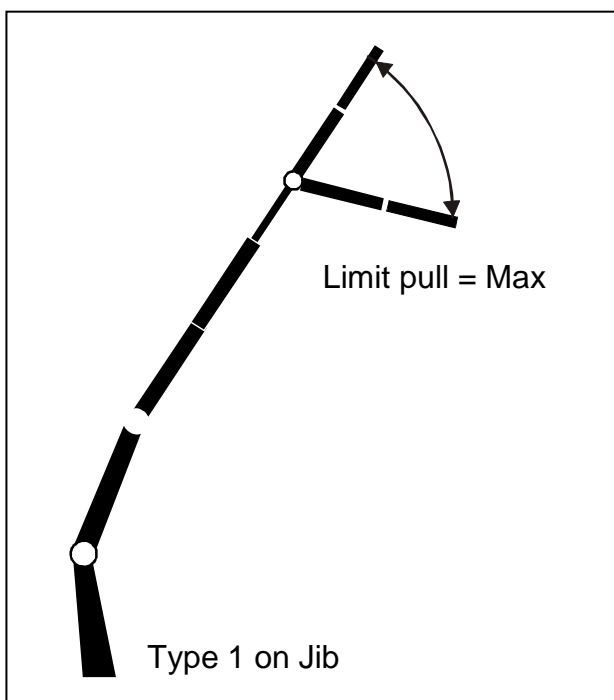
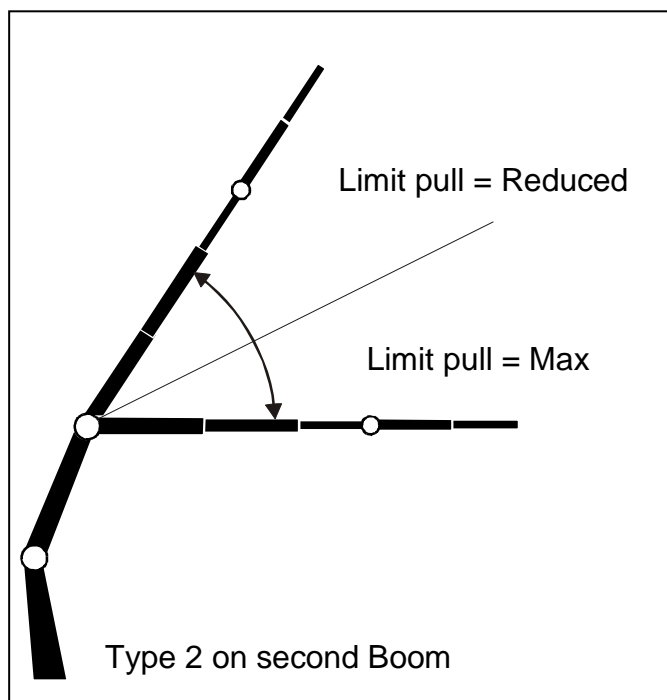
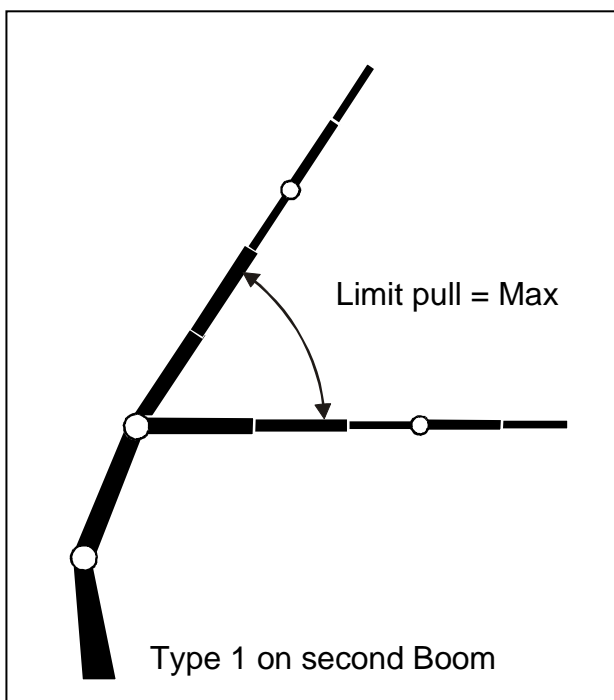

## ROTATION CONTROL

The crane can be installed on a truck which is not stable on all crane 360° of rotation. In this case, the crane needs to be 'downgraded' when it operates in the unstable area, case 1, or it may be even necessary to prevent the crane from reaching that area, case 2, as the boom weight alone might overturn the vehicle.

To manage this situation, the system will be equipped with two micro switches, activated by a cam, which indicate in which rotation area the crane is.

In case 1, the pressure maximum limit will have to be set in relation to the truck stability characteristics in the unstable area. In this way, the limiting device will create two separate crane operation areas: a stable area where the crane can be used at 100% of its capacity, and an unstable area where the crane will be downgraded. The shift from the stable to the unstable area will be possible only if the crane 'load' is lower than the limit value for the unstable area. Otherwise the shift will be blocked.

In case 2, the unstable area pressure limit will be set on zero. The limiting device will create two operating areas: a stable area where the crane can be used at 100% of its capacity, and an unstable one where the crane cannot be used. The shift from the stable to the unstable area will never be allowed.

The following figures show possible operating conditions and allowed/non-allowed rotation movements.

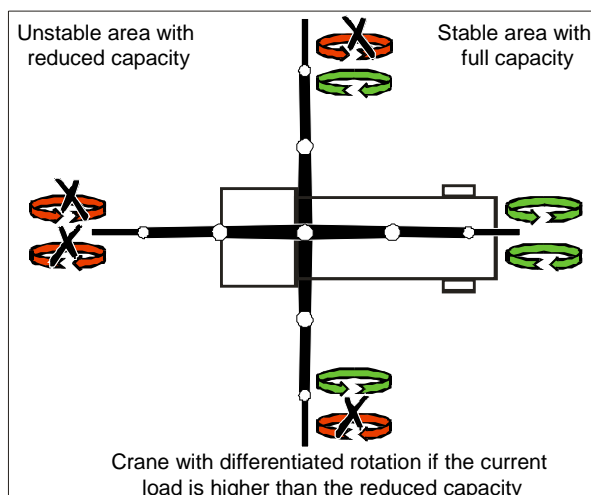
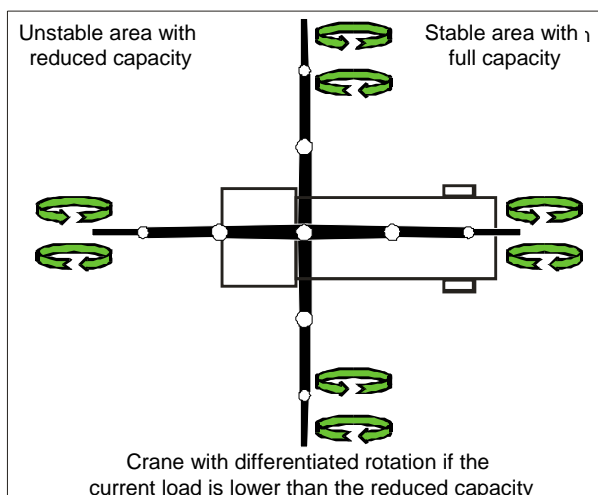
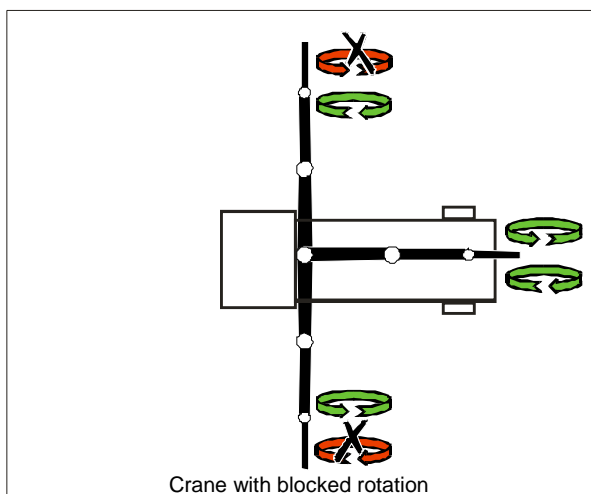
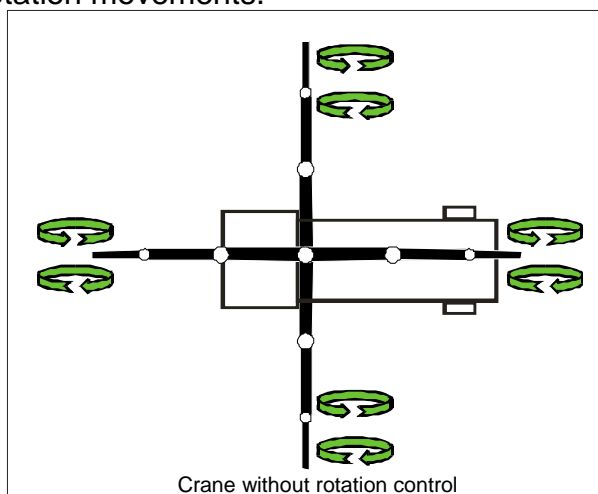

## ROTATION CONTROL

The system updates the crane usage percentage depending on the area where the crane is operating.

The LEDs on the main and secondary panels show the usage state in the operating area.



The usage percentage values for individual jacks are shown on the display in relation to the operating area.

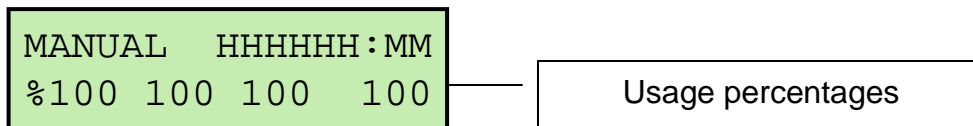

## MOMENT LIMITING DEVICE DISABLING

The system is equipped with the limiting device disabling function, which allows to perform one single descent movement of the primary boom, the secondary boom, or the jib whenever it is impossible to carry out one of the manoeuvres reducing the crane overturning moment, allowed in case of block (see moment limiting device).

This procedure can only be enabled in case of block by pressing the 'RESET' key



When the key is pressed, the red LED will switch on constantly for 10 seconds. During such time span the descent manoeuvre required can be enabled.



After the 10 seconds, the red LED switches off and the procedure needs to be started all over again .

The descent manoeuvre selected will stay enabled for 5 seconds maximum.

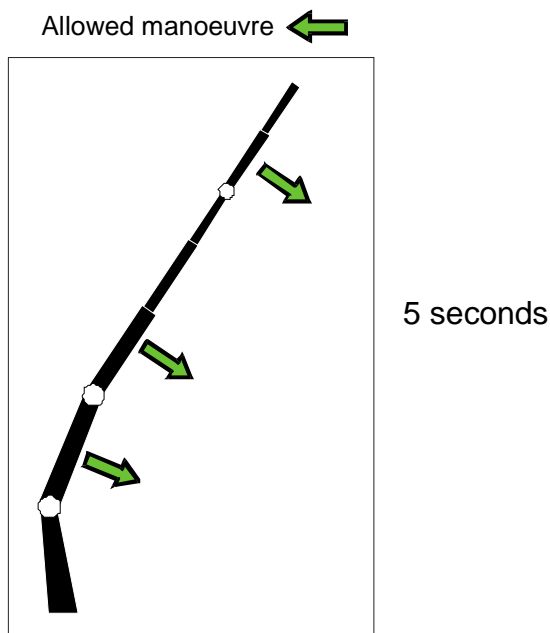

During the descent, the system will keep controlling the pressure inside the crane jacks. If the pressure drops and becomes lower than the blocking pressure, the system will allow the manoeuvre to be continued, as this will be considered not dangerous; if the pressure increases or does not drop, the crane will be blocked again and it will not be possible to re-activate the disabling procedure for 30 seconds, as shown by the flashing red LED.



The same procedure can also be started by pressing the dedicated key located on the radio control keypad.

## EQUIPMENT ACTIVATION

In order to be used, the crane's optional functions: Jib, Winch and Rotor/Bucket, if present, need to be activated by pressing the relevant keys:



The activation allows for the operation of the specific piece of equipment, which otherwise could not be used. Moreover, if an attempt is made to use a disabled piece of equipment, all other manoeuvres too will be blocked until the manoeuvre related to the disabled piece of equipment is interrupted.

The presence of the Jib or Winch, regardless of the enabling of their functions, will result in the related values being shown on the display:

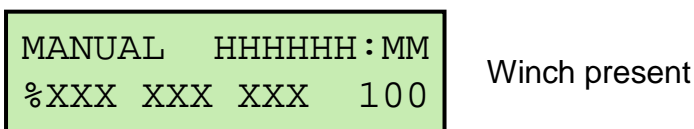
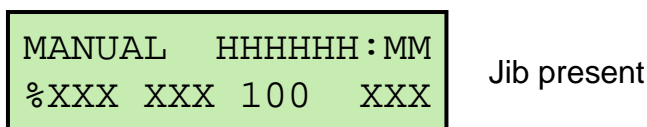

Moreover, the pressure or pull limitations related to these pieces of equipment will be enabled even if the pieces of equipment have not been enabled.

The use of the Rotor/Bucket implies a downgrading of the crane capacity. Therefore, when these pieces of equipment are enabled the crane will be blocked at lower operating pressures.

## ALARM BY-PASS

The system allows to bypass the alarms caused by sensor failures or malfunctioning, thus enabling to complete operations and fold the crane away.

In the event of an alarm, the crane will be immediately stopped. The block can be bypassed by keeping the 'RESET' key pressed.



While the key is being pressed, the alarm message will disappear from the display.

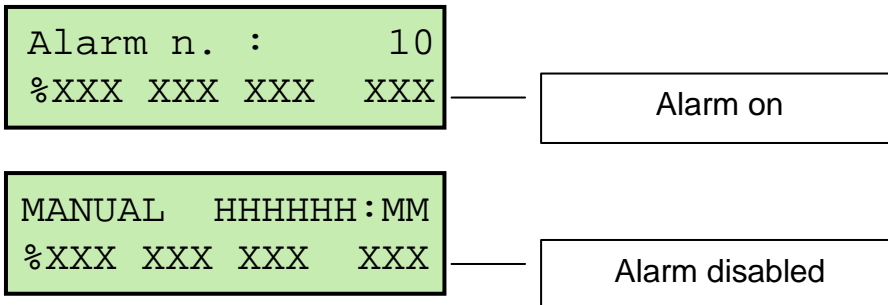

## OIL FILTERS INSPECTION

As an option, the crane can be fitted with oil filters. The system is connected to the sensors installed on the filters and checks their clogging. In case of prolonged filter clogging, for a time span longer than the one set by the manufacturer, the crane can no longer be operated.

The display will show that the filter is clogging by displaying the following flashing message:

FILTER
%XXX XXX XXX XXX

In the event of a block caused by the clogging of a filter, this condition will be highlighted as follows:

STOP FILTER
%XXX XXX XXX XXX

## RADIO CONTROL

The radio control allows to operate the crane achieving better performances. Indeed, the cranes equipped with an optional radio control ensure higher performances than a manually operated crane, because this configuration allows to control the crane's dynamics: the crane could have a higher capacity, but limited speed, in order to prevent excessive strain on the frame due to specific settings.

Consensus to movements is given by a signal sent by the radio control to the limiting device. The signal is activated only when a lever on the radio control is being moved, so as to prevent crane manual operation when the radio control is enabled.

The radio-controlled operation mode is activated by pressing the 'RADIO' key.



The display will show that the mode is enabled as follows:

```
RADIO   HHHHHH : MM  
%XXX  XXX  XXX  XXX
```

The crane cannot be remote-controlled if such mode has not been activated

## VPS

The VPS function manages the crane operating speed in relation to the current load percentage: in relation to two load percentage thresholds, 80% and 90%, two crane speed reductions will occur. One single speed reduction threshold may be enabled during calibration.

In practical terms, when the usage percentage reaches the first threshold, the crane movement speed will be reduced for the first time; when the second threshold is reached, the speed will be further reduced. Reduced movement speeds are set in the radio control.

Speed reductions take place immediately both if the usage percentage reaches a reduction threshold during a manoeuvre and if a threshold is reached when the crane is not moving.

The crane will go back to a higher speed only when the usage percentage is lower than a threshold and there are no ongoing manoeuvres; therefore, if a manoeuvre is started at a reduced speed and the usage percentage drops below a speed reduction threshold, the crane speed will not increase until the ongoing manoeuvre has been completed and a new movement is started.

## JACK ARMS CONTROL

The system can be expanded to communicate with an optional control unit for the control and movement of beams and jack arms.

The standard system is equipped with the following function:

The key  enables and disables the jack arms movement;

The display shows that the management is enabled as follows:

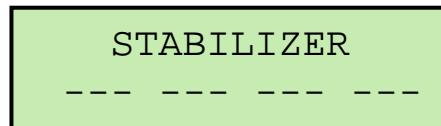

At this stage, unlike in the 'Crane' operation, the crane general exhaust valve is normally enabled, to allow for jack arms movement. The use of functions moving the crane cause the general valve to switch off, stopping the movements.

## MAINTENANCE

During crane life, a series of scheduled maintenance operations will need to be carried out. The main panel display will flash showing which maintenance operation is required.

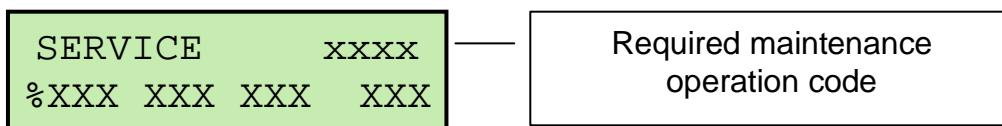

The license will be responsible for carrying out the necessary maintenance and for saving, using the dedicated menu only accessible by entering a password, the maintenance operations performed. Such procedure is required to eliminate the message from the display and to ensure that the subsequent maintenance operations required are duly displayed.

SERVICE MENU	Maintenance management menu
Normal: xxxx	xxxx = code of the ordinary maintenance operation required
Extra: 0/1	0 = no extraordinary maintenance 1 = extraordinary maintenance required
S. done 1: code	code = code of maintenance operation performed
S. done 2: code	code = code of maintenance operation performed
S. done 3: code	code = code of maintenance operation performed
S. done 4: code	code = code of maintenance operation performed
S. done 5: code	code = code of maintenance operation performed
S. done 6: code	code = code of maintenance operation performed
S. done 7: code	code = code of maintenance operation performed
S. done 8: code	code = code of maintenance operation performed
Service done?	maintenance performed confirmation

The 'Normal' maintenance operations are scheduled at the programmed intervals listed below and will be signalled by the appearance of the SERVICE wording:

SERVICE 10	After 10 hours
SERVICE 100	After 100 hours
SERVICE 500	After 500 hours
SERVICE 1000	After 1,000 hours
SERVICE xxxx	Every 1,000 hours

### LIST OF THE CODES OF MAINTENANCE OPERATIONS PERFORMED

The following table includes a list of the codes of the possible maintenance operations to be carried out during crane life.

No.	Maintenance Operation Description
1	Drain filter Cartridge Replacement
2	Infeed Pressurised Filter Cartridge Replacement
3	Hydraulic Oil Topping Up
4	Hydraulic Oil Replacement
5	
6	Greasing of Crane Extension Booms
7	Greasing of Crane Hinges Bushes
8	Greasing of Rotation or Fifth Wheel Support Assembly Bushes
9	Greasing of Crane Jacks Bushes
10	Greasing of Jib Extension Booms
11	Greasing of Jib Hinges Bushes
12	Greasing of Jib Jacks Bushes
13	
14	
15	Inspection of Crane Anchoring Tension Wires Tightening
16	Inspection of Controls and Tank Supports Screws Tightening
17	Verification of Pin Retainers Screws Tightening
18	Verification of Sliding Shoes and Sliding shoes Stopper Screws Tightening
19	Verification of Extension Booms Adjusters Screws Tightening
20	Verification of Jack Arms Adjusters Screws Tightening
21	Verification of Basement Adjusters Screws Tightening
22	Verification of Rack Adjuster Screws Tightening
23	Verification of Geared Motor or Rotation Cylinders Screws Tightening
24	Verification of Fifth Wheel Screws Tightening
25	Verification of Play Adjustment Elements (Plates and/or Shims)
26	
27	Verification of Distributor Fittings Tightening
28	Verification of Flexible Hoses Fittings Tightening
29	Verification of Pipes Tightening
30	
31	Verification of Pump Infeed and Vacuum Connections
32	
33	

**LIST OF THE CODES OF MAINTENANCE OPERATIONS PERFORMED**

No.	Maintenance Operation Description
34	Verification of CRANE STOP operation
35	Verification of Limiting Device operation
36	Verification of Radio Control operation
37	Inspection of all safety devices listed in the User and Maintenance manual
38	Inspection of LIS Device
39	Inspection of Sliding shoes wear and tear conditions
40	
41	Rotation Jacks Valve Calibration
42	1 <sup>st</sup> Boom Jack Valve Calibration
43	2 <sup>nd</sup> Boom Jack Valve Calibration
44	Jib Jack Valve Calibration
45	Crane 1 <sup>st</sup> extension boom Jack Valve Calibration
46	Jib 1 <sup>st</sup> extension boom Jack Valve Calibration
47	
48	Crane Distributor maximum pressure Valve Calibration
49	Jack Arms Distributor maximum pressure Valve Calibration
50	
51	Rotation Element distributor Partial Valves Calibration
52	1 <sup>st</sup> Boom Element distributor Partial Valves Calibration
53	2 <sup>nd</sup> Boom Element distributor Partial Valves Calibration
54	Crane Extension Booms Element distributor Partial Valves Calibration
55	Jib Element distributor Partial Valves Calibration
56	Jib Extension Booms Element distributor Partial Valves Calibration
57	Winch Element distributor Partial Valves Calibration
58	1 <sup>st</sup> Activation Element distributor Partial Valves Calibration
59	2 <sup>nd</sup> Activation Element distributor Partial Valves Calibration
60	
61	
62	
63	
64	
65	

**LIST OF THE CODES OF MAINTENANCE OPERATIONS PERFORMED**

No.	Maintenance Operation Description
66	
67	Rotation Jacks Gaskets Replacement
68	1 <sup>st</sup> Boom Jack Gaskets Replacement
69	2 <sup>nd</sup> Boom Jack Gaskets Replacement
70	Jib Jack Gaskets Replacement
71	Jack Arms Gaskets Replacement
72	1 <sup>st</sup> Extension Boom Jack Gaskets Replacement
73	2 <sup>nd</sup> Extension Boom Jack Gaskets Replacement
74	3 <sup>rd</sup> Extension Boom Jack Gaskets Replacement
75	4 <sup>th</sup> Extension Boom Jack Gaskets Replacement
76	5 <sup>th</sup> Extension Boom Jack Gaskets Replacement
77	6 <sup>th</sup> Extension Boom Jack Gaskets Replacement
78	7 <sup>th</sup> Extension Boom Jack Gaskets Replacement
79	8 <sup>th</sup> Extension Boom Jack Gaskets Replacement
80	9 <sup>th</sup> Extension Boom Jack Gaskets Replacement
81	10 <sup>th</sup> Extension Boom Jack Gaskets Replacement
82	Jib 1 <sup>st</sup> Extension Boom Jack Gaskets Replacement
83	Jib 2 <sup>nd</sup> Extension Boom Jack Gaskets Replacement
84	Jib 3 <sup>rd</sup> Extension Boom Jack Gaskets Replacement
85	Jib 4 <sup>th</sup> Extension Boom Jack Gaskets Replacement
86	Jib 5 <sup>th</sup> Extension Boom Jack Gaskets Replacement
87	
88	Replacement of Crane Distributor Gaskets on Lever-side
89	Replacement of Crane Distributor Gaskets between sections
90	Replacement of Crane Distributor Gaskets on Radio Module-side
91	Replacement of Crane Distributor Gaskets on Radio Module-side
92	
93	Replacement of Jack Arms Distributor Gaskets on Lever side
94	Replacement of Jack Arms Distributor Gaskets between sections
95	
96	
100	

**LIST OF THE CODES OF MAINTENANCE OPERATIONS PERFORMED**

No.	Maintenance Operation Description
101	
102	
103	Jack Arms Valve Replacement
104	Rotation Valve Replacement
105	1 <sup>st</sup> Boom Valve Replacement
106	2 <sup>nd</sup> Boom Valve Replacement
107	Crane 1 <sup>st</sup> Extension Boom Jack Valve Replacement
108	Jib Valve Replacement
109	Jib 1 <sup>st</sup> Extension Boom Jack Valve Replacement
110	
111	Crane 1 <sup>st</sup> -2 <sup>nd</sup> Extension Boom Sequence Valve Replacement
112	Crane 2 <sup>nd</sup> -3 <sup>rd</sup> Extension Boom Sequence Valve Replacement
113	Crane 3 <sup>rd</sup> -4 <sup>th</sup> Extension Boom Sequence Valve Replacement
114	Crane 4 <sup>th</sup> -5 <sup>th</sup> Extension Boom Sequence Valve Replacement
115	Crane 5 <sup>th</sup> -6 <sup>th</sup> Extension Boom Sequence Valve Replacement
116	Crane 6 <sup>th</sup> -7 <sup>th</sup> Extension Boom Sequence Valve Replacement
117	Crane 7 <sup>th</sup> -8 <sup>th</sup> Extension Boom Sequence Valve Replacement
118	Crane 8 <sup>th</sup> -9 <sup>th</sup> Extension Boom Sequence Valve Replacement
119	Crane 9 <sup>th</sup> -10 <sup>th</sup> Extension Boom Sequence Valve Replacement
120	
121	Jib 1 <sup>st</sup> -2 <sup>nd</sup> Extension Sequence Valve Replacement
122	Jib 2 <sup>nd</sup> -3 <sup>rd</sup> Extension Sequence Valve Replacement
123	Jib 3 <sup>rd</sup> -4 <sup>th</sup> Extension Sequence Valve Replacement
124	Jib 4 <sup>th</sup> -5 <sup>th</sup> Extension Sequence Valve Replacement
125	
126	
127	
128	

**LIST OF THE CODES OF MAINTENANCE OPERATIONS PERFORMED**

<b>No.</b>	<b>Maintenance Operation Description</b>
129	
130	Jack Arm Replacement
131	Rotation Jack Replacement
132	1 <sup>st</sup> Boom Jack Replacement
133	2 <sup>nd</sup> Boom Jack Replacement
134	Crane 1 <sup>st</sup> Extension Boom Jack Replacement
135	Jib Jack Replacement
136	Jib 1 <sup>st</sup> Extension Boom Jack Replacement
137	Jib 2 <sup>nd</sup> Extension Boom Jack Replacement
138	Jib 3 <sup>rd</sup> Extension Boom Jack Replacement
139	Jib 4 <sup>th</sup> Extension Boom Jack Replacement
140	Jib 5 <sup>th</sup> Extension Boom Jack Replacement
141	
142	
143	Replacement of Crane Complete distributor
144	Replacement of Crane Distributor Section Element
145	Replacement of Distributor Radio Module
146	Replacement of Distributor Cursor
147	Replacement of Distributor Exhaust Valve
148	Replacement of Distributor Exhaust Valve Coil
149	Replacement of Crane Distributor maximum pressure Valve
150	
151	
152	Jack Arms Complete distributor Replacement
153	Jack Arms Distributor maximum pressure Valve Replacement
154	
155	
156	Crane-Jack Arms Switch Replacement
157	
158	Flexible Hoses Replacement
159	
160	

**LIST OF THE CODES OF MAINTENANCE OPERATIONS PERFORMED**

<b>No.</b>	<b>Maintenance Operation Description</b>
161	
162	
163	Rotation Bushes Replacement
164	Replacement of 1 <sup>st</sup> Boom – Column Hinge Bushes
165	Replacement of 1 <sup>st</sup> Boom – 2 <sup>nd</sup> Boom Hinge Bushes
166	Replacement of Jib Coupling Bushes
167	Replacement of 1 <sup>st</sup> Boom Connecting Rods Bushes
168	Replacement of 2 <sup>nd</sup> Boom Connecting Rods Bushes
169	Replacement of Jib Connecting Rods Bushes
170	Replacement of 1 <sup>st</sup> Boom Short Connecting Rod Bushes
171	Replacement of 2 <sup>nd</sup> Boom Short Connecting Rod Bushes
172	Replacement of Jib Short Connecting Rod Bushes
173	Replacement of 1 <sup>st</sup> Boom Jack Bushes
174	Replacement of 2 <sup>nd</sup> Boom Jack Bushes
175	Replacement of Jib Jack Bushes
176	
177	Replacement of Jack Arms Sliding shoes
178	Replacement of Rack Adjuster Sliding shoe
179	2 <sup>nd</sup> Boom Sliding shoes Replacement
180	Replacement of 1 <sup>st</sup> Extension Boom Sliding shoes
181	Replacement of 2 <sup>nd</sup> Extension Boom Sliding shoes
182	Replacement of 3 <sup>rd</sup> Extension Boom Sliding shoes
183	Replacement of 4 <sup>th</sup> Extension Boom Sliding shoes
184	Replacement of 5 <sup>th</sup> Extension Boom Sliding shoes
185	Replacement of 6 <sup>th</sup> Extension Boom Sliding shoes
186	Replacement of 7 <sup>th</sup> Extension Boom Sliding shoes
187	Replacement of 8 <sup>th</sup> Extension Boom Sliding shoes
188	Replacement of 9 <sup>th</sup> Extension Boom Sliding shoes
189	Replacement of 10 <sup>th</sup> Extension Boom Sliding shoes
190	
191	
192	

**LIST OF THE CODES OF MAINTENANCE OPERATIONS PERFORMED**

<b>No.</b>	<b>Maintenance Operation Description</b>
193	
194	Jib Boom Sliding shoes Replacement
195	Replacement of Jib 1 <sup>st</sup> Extension Boom Sliding shoes
196	Replacement of Jib 2 <sup>nd</sup> Extension Boom Sliding shoes
197	Replacement of Jib 3 <sup>rd</sup> Extension Boom Sliding shoes
198	Replacement of Jib 4 <sup>th</sup> Extension Boom Sliding shoes
199	Replacement of Jib 5 <sup>th</sup> Extension Boom Sliding shoes
200	
201	Complete Basement Replacement
202	Rotation Support Replacement
203	Replacement of Stabilising Rod on Distributor Side
204	Replacement of Stabilising Rod on Passenger Side
205	Column Replacement
206	1 <sup>st</sup> Boom Replacement
207	2 <sup>nd</sup> Boom Replacement
208	1 <sup>st</sup> Extension Boom Replacement
209	2 <sup>nd</sup> Extension Boom Replacement
210	3 <sup>rd</sup> Extension Boom Replacement
211	4 <sup>th</sup> Extension Boom Replacement
212	5 <sup>th</sup> Extension Boom Replacement
213	6 <sup>th</sup> Extension Boom Replacement
214	7 <sup>th</sup> Extension Boom Replacement
215	8 <sup>th</sup> Extension Boom Replacement
216	9 <sup>th</sup> Extension Boom Replacement
217	10 <sup>th</sup> Extension Boom Replacement
218	Replacement of Jib Coupling or 'Top Roller' Coupling
219	Jib Boom Replacement
220	Replacement of Jib 1 <sup>st</sup> Extension Boom
221	Replacement of Jib 2 <sup>nd</sup> Extension Boom
222	Replacement of Jib 3 <sup>rd</sup> Extension Boom
223	Replacement of Jib 4 <sup>th</sup> Extension Boom
224	Replacement of Jib 5 <sup>th</sup> Extension Boom

**LIST OF THE CODES OF MAINTENANCE OPERATIONS PERFORMED**

<b>No.</b>	<b>Maintenance Operation Description</b>
225	
226	
227	
228	Replacement of Main Limiting Device
229	Replacement of Auxiliary Limiting Device
230	
231	Main Wiring Replacement
232	
233	Replacement of Basic Crane on-off Mercury Micro
234	Replacement of Jib on-off Mercury Micro
235	Replacement of Basic Crane Proportional Micro
236	Replacement of Jib Proportional Micro
237	
238	Replacement of Basic Crane Pressure Transducer
239	Replacement of Jib Pressure Transducer
240	
241	Illuminated-Sound Warning Replacement
242	
243	Emergency Knob Replacement
244	PWR Fuse Replacement
245	XS2 Cable Replacement
246	XS3 Cable Replacement
247	XS4 Cable Replacement
248	XS5 Cable Replacement
249	XS6 Cable Replacement
250	XS7 Cable Replacement
251	XS8 Cable Replacement
252	XS9 Cable Replacement
253	XS10 Cable Replacement
254	XS11 Cable Replacement
255	
256	
257	

**LIST OF THE CODES OF MAINTENANCE OPERATIONS PERFORMED**

<b>No.</b>	<b>Maintenance Operation Description</b>
258	Winch Limiting Device Box Replacement
259	Winch Extensometer Replacement
260	Rope Limit Micro Switch Replacement
261	Complete Winch Replacement
262	
263	Winch 'Top Roller' / Winch Rope Block Replacement
264	Winch Rope Replacement
265	
266	
267	
268	Crane Mobile Hook Replacement
269	Crane Fixed Hook Replacement
270	Jib Hook Replacement
271	
272	Exchanger Replacement
273	Exchanger Switch-on Device Replacement
274	Exchanger Thermostat Replacement
275	
276	
277	General Visual Inspection of Crane conditions
278	
279	General Visual Inspection of Hinge Play
280	
281	General Visual Inspection of Steel Structural Work Visible Weldings
282	
283	Complete Crane Disassembly for Inspection of Individual Components
284	
285	
286	
287	
288	
289	
290	

## MAINTENANCE OPERATIONS REQUIRED FOR SCHEDULED SERVICING (Periodicity Table)

The minimum operations required for the 10-hour servicing are listed below.

Maintenance Code	Description
2	Infeed Pressurised Filter Cartridge Replacement
15	Verification of Crane Anchoring Tension Wires Tightening
22	Verification of Rack Adjuster Tightening
31	Inspection of Pump Vacuum and Infeed Connections
34	Inspection of CRANE STOP operation
35	Inspection of Limiting device Operation

The minimum operations required for the 100-hour servicing are listed below

Maintenance Code	Description
15	Verification of Crane Anchoring Tension Wires Tightening
22	Verification of Rack Adjuster Tightening
31	Inspection of Pump Vacuum and Infeed Connections
3	Hydraulic Oil Topping Up
27	Verification of Distributor Fittings Tightening
28	Verification of Flexible Hoses Fittings Tightening
29	Verification of Pipes Tightening
1	Drain Filter Cartridge Replacement
34	Inspection of CRANE STOP operation
35	Inspection of Limiting device Operation

The minimum operations required for the 500-hour (or 6 months) servicing are listed below.

Maintenance Code	Description
6	Crane Extension Booms Greasing
7	Crane Hinges Bushes Greasing
8	Rotation or Fifth Wheel Support Assembly Greasing
9	Crane Jacks Arms Bushes Greasing
10	Jib Extension Booms Greasing
11	Jib Hinges Bushes Greasing
12	Jib Jacks Bushes Greasing
39	Inspection of Sliding shoes wear and tear conditions
34	Verification of CRANE STOP operation
35	Verification of Limiting device Operation
36	Verification of Radio Control Operation
37	Inspection of all safety devices listed in the User and Maintenance manual
15	Verification of Crane Anchoring Tension Wires Tightening
22	Verification of Rack Adjuster Tightening

The minimum operations required for the 1000-hour servicing (or once a year) and for each subsequent servicing, scheduled every 1000 hours, are listed below.

Maintenance Code	Description
15	Verification of Crane Anchoring Tension Wires Tightening
16	Verification of Controls and Tank Support Screws Tightening
17	Verification of Pin Retainers Screws Tightening
18	Verification of Sliding shoes and Sliding shoes Stopper Screws Tightening
19	Verification of Extension Booms Adjusters Screws Tightening
20	Verification of Jack Arms Adjusters Screws Tightening
21	Verification of Basement Adjusters Screws Tightening
22	Verification of Rack Adjuster Screws Tightening
23	Verification of Rotation or Geared Motor Cylinders Screws Tightening
24	Verification of Bucket Screws Tightening
25	Inspection of Play Adjustment Elements (Plates and/or Shims)
1	Drain filter Cartridge Replacement
2	Infeed Pressurised Filter Cartridge Replacement
4	Hydraulic Oil Replacement
41	Rotation Jacks Valve Calibration
42	1 <sup>st</sup> Boom Jack Valve Calibration
43	2 <sup>nd</sup> Boom Jack Valve Calibration
44	Jib Jack Valve Calibration
45	Crane 1 <sup>st</sup> extension boom Jack Valve Calibration
46	Jib 1 <sup>st</sup> extension boom Jack Valve Calibration
48	Crane Distributor maximum pressure Valve Calibration
49	Jack Arms Distributor maximum pressure Valve Calibration
51	Rotation Element distributor Partial Valves Calibration
52	1 <sup>st</sup> Boom Element distributor Partial Valves Calibration
53	2 <sup>nd</sup> Boom Element distributor Partial Valves Calibration
54	Crane Extension Booms Element distributor Partial Valves Calibration
55	Jib Element distributor Partial Valves Calibration
56	Jib Extension Booms Element distributor Partial Valves Calibration
57	Winch Element distributor Partial Valves Calibration
58	1 <sup>st</sup> Activation Element distributor Partial Valves Calibration
59	2 <sup>nd</sup> Activation Element distributor Partial Valves Calibration
277	General Visual Inspection of Crane conditions
279	General Visual Inspection of Hinge Play
281	General Visual Inspection of Steel Structural Work Visible Weldings
37	Inspection of all safety devices listed in the User and Maintenance manual
6	Crane Extension Booms Greasing
7	Crane Hinges Bushes Greasing
8	Rotation or Fifth Wheel Support Assembly Greasing
9	Crane Jacks Bushes Greasing
10	Jib Extension Booms Greasing
11	Jib Hinges Bushes Greasing
12	Jib Jacks Bushes Greasing
39	Inspection of Sliding shoes wear and tear conditions

## USAGE STATISTICS

The system constantly updates a series of data showing how the crane is being used. All data can be displayed and downloaded using a dedicated PC programme. All calculated data are shown in the following table.

	<b>Name</b>	<b>Description</b>
0	BBS_TOTALtime	crane life
1	BBS_WORKtime	crane operation time
2	BBS_nReset	number of limiting device disabling activations
3	BBS_BR1nBlocchi	number of primary boom overloads
4	BBS_BR2nBlocchi	number of secondary boom overloads
5	BBS_BRJnBlocchi	number of Jib boom overloads
6	BBS_BR1tim_10_70	main boom operation between 10% and 70% of nominal pressure – time in seconds
7	BBS_BR1tim_70_80	main boom operation between 70% and 80% of nominal pressure – time in seconds
8	BBS_BR1tim_80_90	main boom operation between 80% and 90% of nominal pressure – time in seconds
9	BBS_BR1tim_90_100	main boom operation between 90% and 100% of nominal pressure – time in seconds
10	BBS_BR1tim_100_110	main boom operation between 100% and 110% of nominal pressure – time in seconds
11	BBS_BR1tim_110_140	main boom operation exceeding 110% of nominal pressure – time in seconds
12	BBS_BR2tim_10_70	secondary boom operation between 10% and 70% of nominal pressure – time in seconds
13	BBS_BR2tim_70_80	secondary boom operation between 70% and 80% of nominal pressure – time in seconds
14	BBS_BR2tim_80_90	secondary boom operation between 80% and 90% of nominal pressure – time in seconds
15	BBS_BR2tim_90_100	secondary boom operation between 90% and 100% of nominal pressure – time in seconds
16	BBS_BR2tim_100_110	secondary boom operation between 100% and 110% of nominal pressure – time in seconds
17	BBS_BR2tim_110_140	secondary boom operation exceeding 110% of nominal pressure – time in seconds
18	BBS_BRJtim_10_70	Jib boom operation between 10% and 70% of nominal pressure – time in seconds
19	BBS_BRJtim_70_80	Jib boom operation between 70% and 80% of nominal pressure – time in seconds
20	BBS_BRJtim_80_90	Jib boom operation between 80% and 90% of nominal pressure – time in seconds
21	BBS_BRJtim_90_100	Jib boom operation between 90% and 100% of nominal pressure – time in seconds
22	BBS_BRJtim_100_110	Jib boom operation between 100% and 110% of nominal pressure – time in seconds
23	BBS_BRJtim_110_140	Jib boom operation exceeding 110% of nominal pressure – time in seconds
24	BBS_nFiltri	number of blocks caused by oil filters
25	BBS_ROTtime	rotation usage time, in seconds
26	BBS_BR1time	first boom movement usage time, in seconds
27	BBS_BR2time	second boom movement usage time, in seconds
28	BBS_BRJtime	Jib movement operation time, in seconds
29	BBS_SF2time	second boom extension usage time, in seconds
30	BBS_SFJtime	Jib extension boom usage time, in seconds
31	BBS_ARJtime	winch usage time, in seconds

## BLACK BOX

The system is fitted with a black box, which records all crane-usage related events.

The Black Box includes three areas:

1. events saving
2. parameter modifications saving
3. saving of maintenance operations performed

The events saved in area 1, up to a maximum number of 2,000, are the following:

Event code	Description
1	Black box startup / resetting
2	TOTAL time resetting
10	Alarms
20	Overloads exceeding 130% of nominal capacity
30	Moment limiting device disabling
40	Filters clogging

Every event saved includes the following fields:

Event Code	Time	Date	Alarm code	Max pressure	Time (hours)	Time (min)	Time (seconds)	***	***	***	***	***	***	***	***
10	12.00.00	20/02/2004	10	3000	1000	30	0	0	0	0	0	0	0	0	0

Area 2 only saves calibration changes up to a maximum number of 2,000:

Event code	Description
100	Data saved with modified parameter(s)

Every event saved includes the following fields:

Event Code	Time	Date	PIN 1	PIN 2	Parameter index	New value	Old value	***	***	***	***	***	***	***
10	12.00.00	20/02/2004	xxxxx	xxxxx	1	1	0	0	0	0	0	0	0	0

Area 3 saves the scheduled maintenance operations carried out, up to a maximum number of 100.

Event code	Description
200	Maintenance operation performed

Event Code	Time	Date	PIN 1	PIN 2	Hours of operat	Scheduled ordinary maintenance	Scheduled extraord. maintenance	Mainten. perform. 1	Mainten. perform. 2	Mainten. perform. 3	Mainten. perform. 4	Mainten. perform. 5	Mainten. perform. 6	Mainten. perform. 7	Mainten. perform. 8
10	12.00.00	20/02/04	xxxxx	xxxxx	1	1	0	0	0	0	0	0	0	0	0

Data contained in the Black Box can be downloaded by means of a dedicated PC programme.

## DISPLAY

### SETTING A VALUE

Values are set as follows:

Select the page where the value is to be set

```
PIN 1:      0
```

Press ENTER



to have the asterisk appear on the above line.

The asterisk shows which figure is about to be modified.

```
PIN 1:      0*
```

Use the +



and -



keys to modify the value.

```
PIN 1:      1*
```

Use the INDEX



key to move the asterisk to another figure.

```
PIN 1:      1*
```

Use the +



and -



keys again to modify the value.

```
PIN 1:      11*
```

## MENU DESCRIPTION AND NAVIGATION

### MAIN MENU

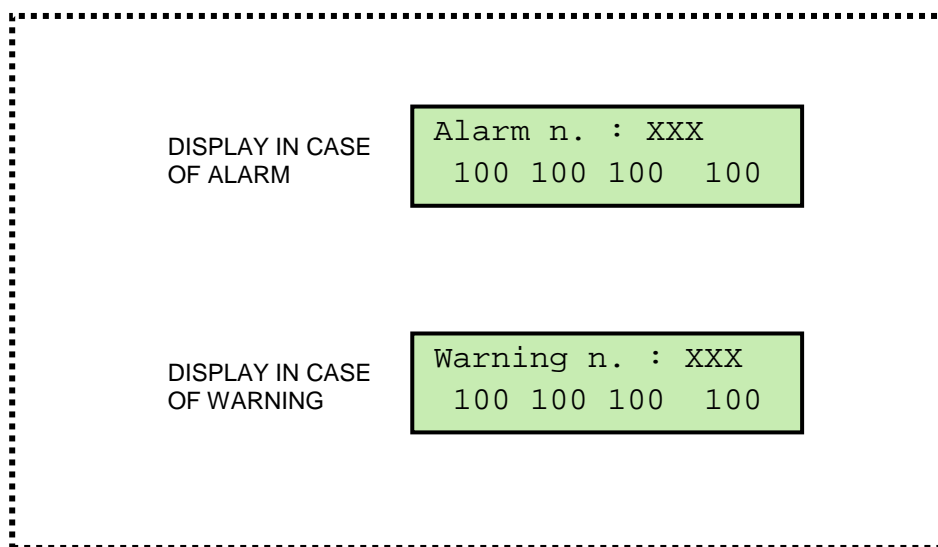
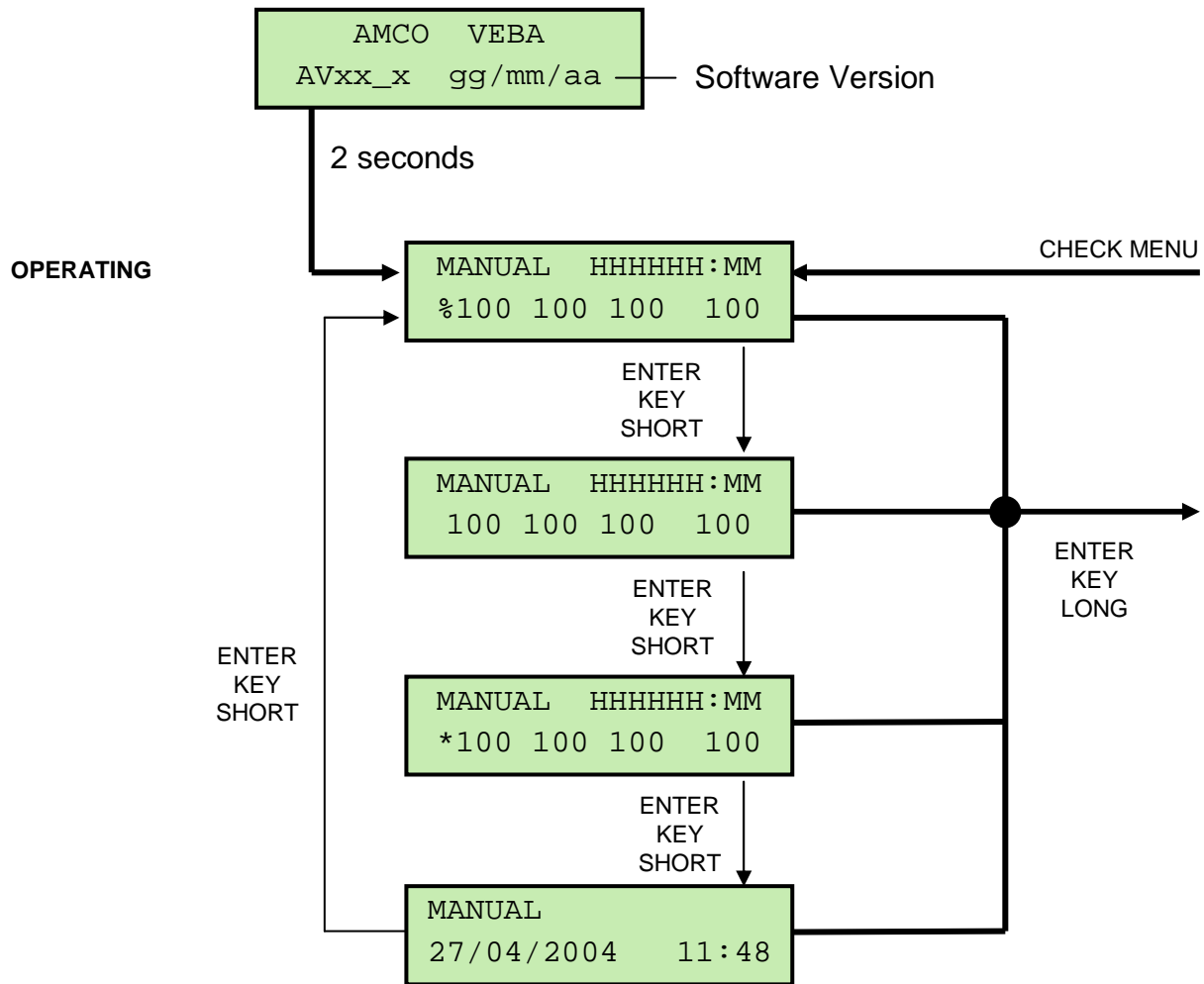

### CHECK MENU

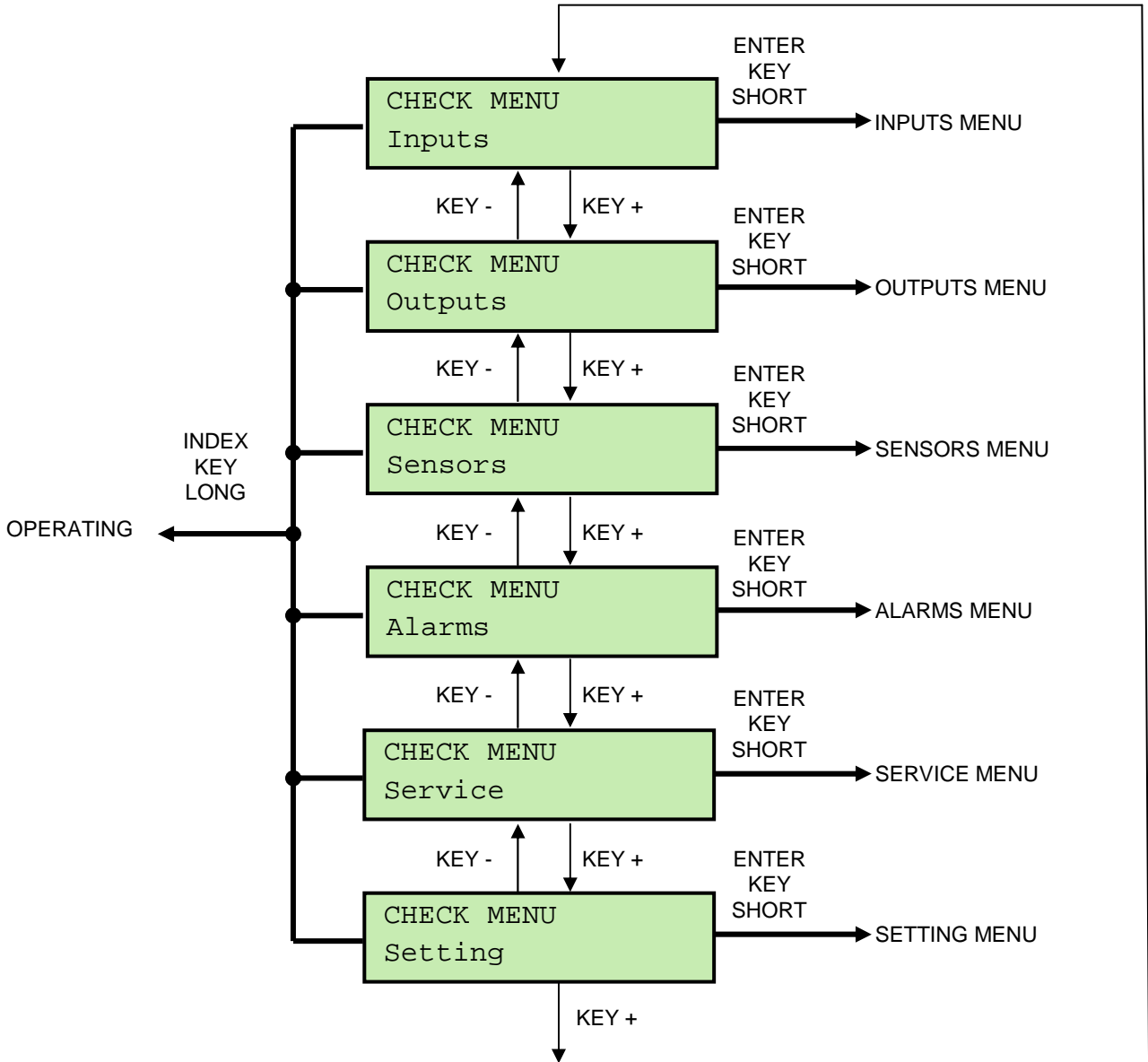

**INPUTS MENU**

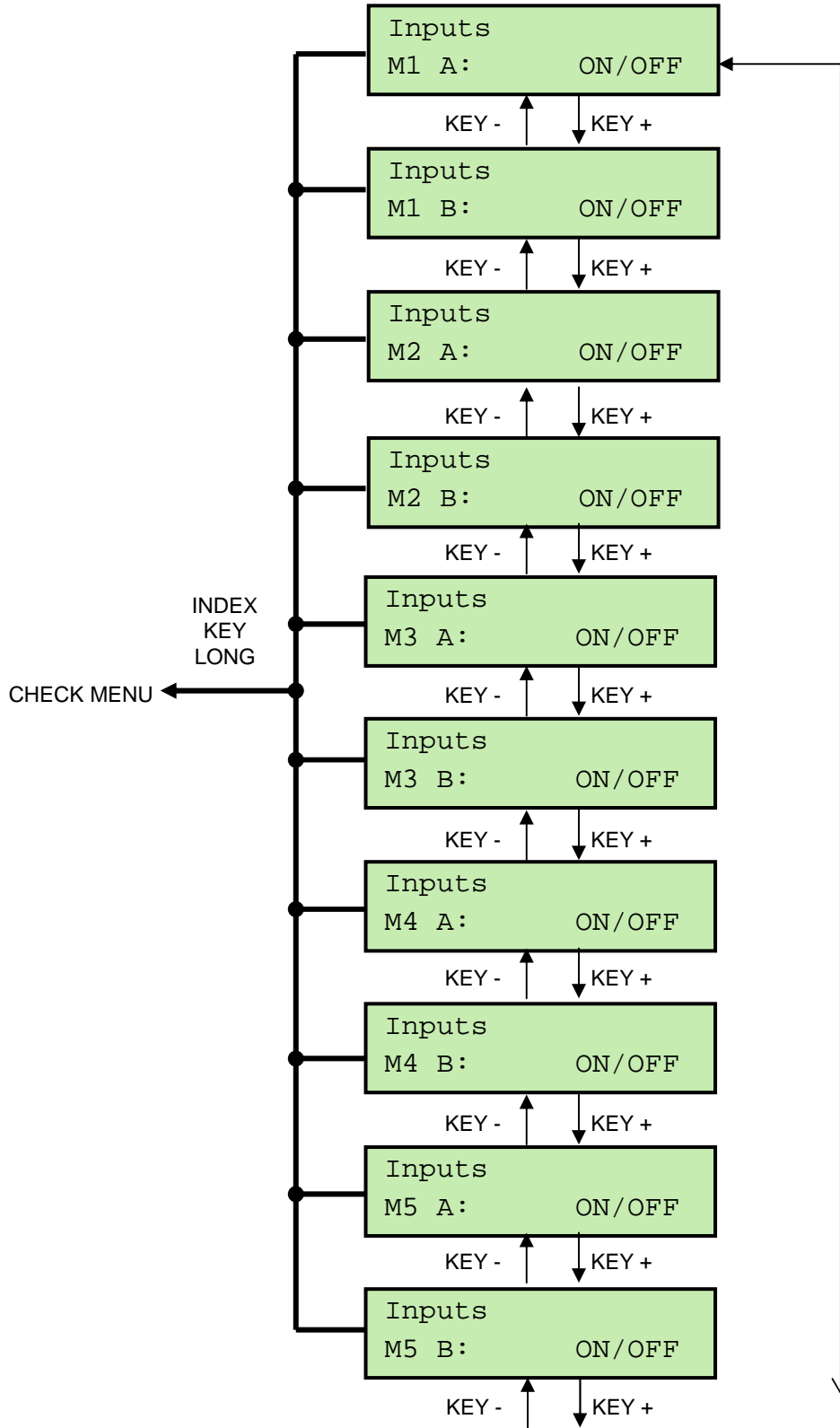

ON = INPUT ENABLED  
 OFF = INPUT DISABLED

## INPUTS MENU

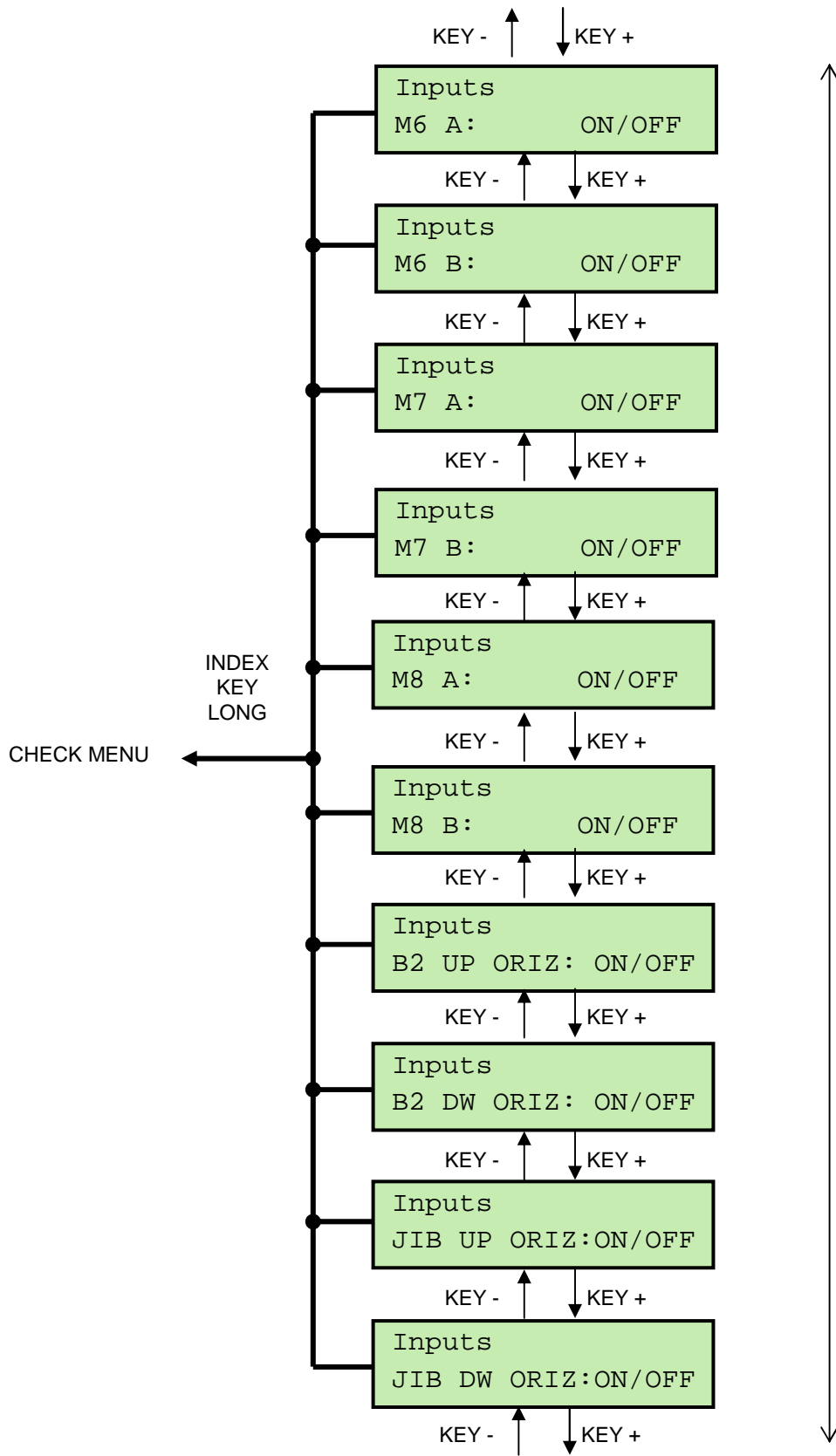

ON = INPUT ENABLED  
OFF = INPUT DISABLED

## INPUTS MENU

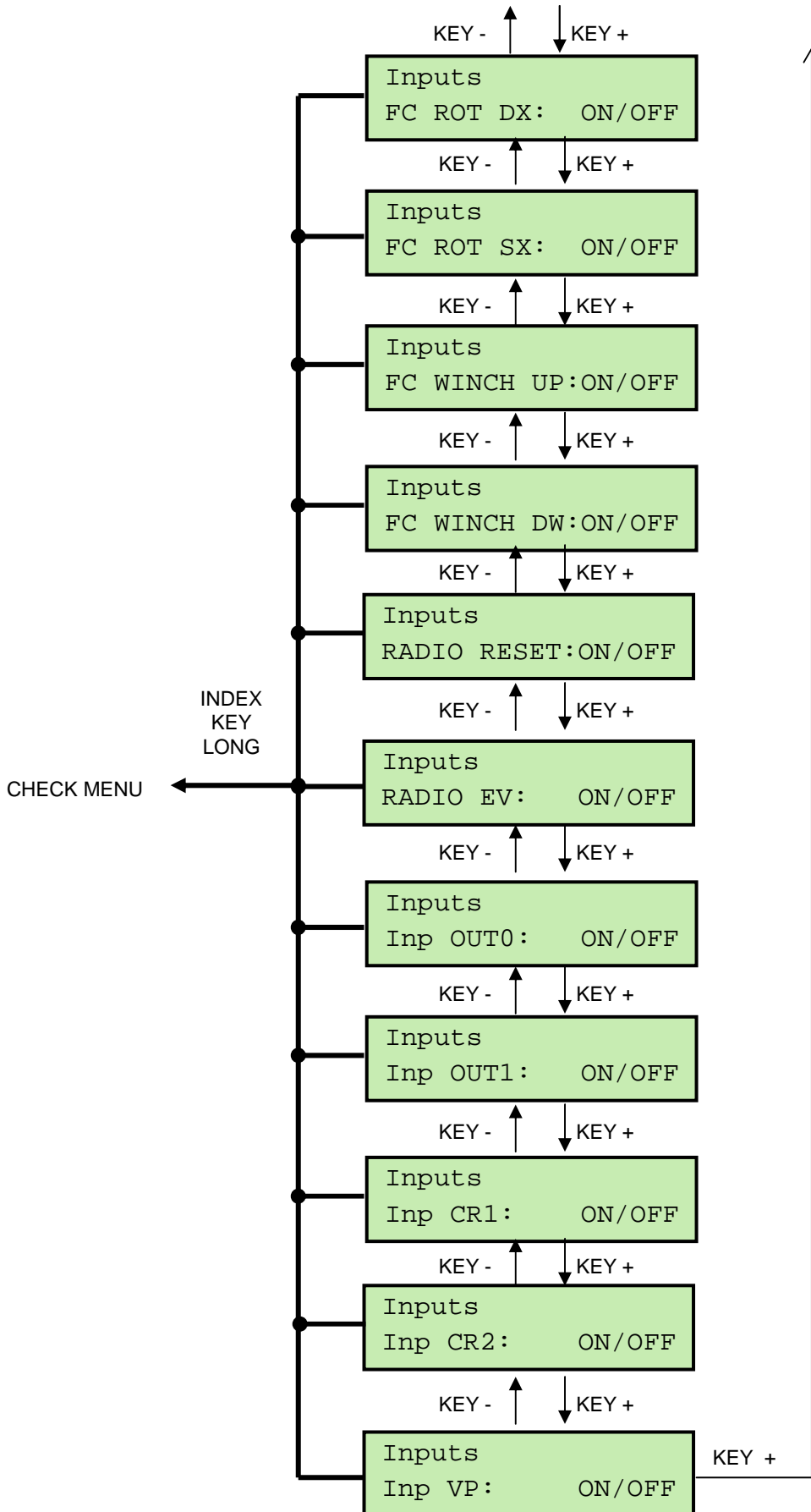

ON = INPUT ENABLED  
 OFF = INPUT DISABLED

## OUTPUTS MENU

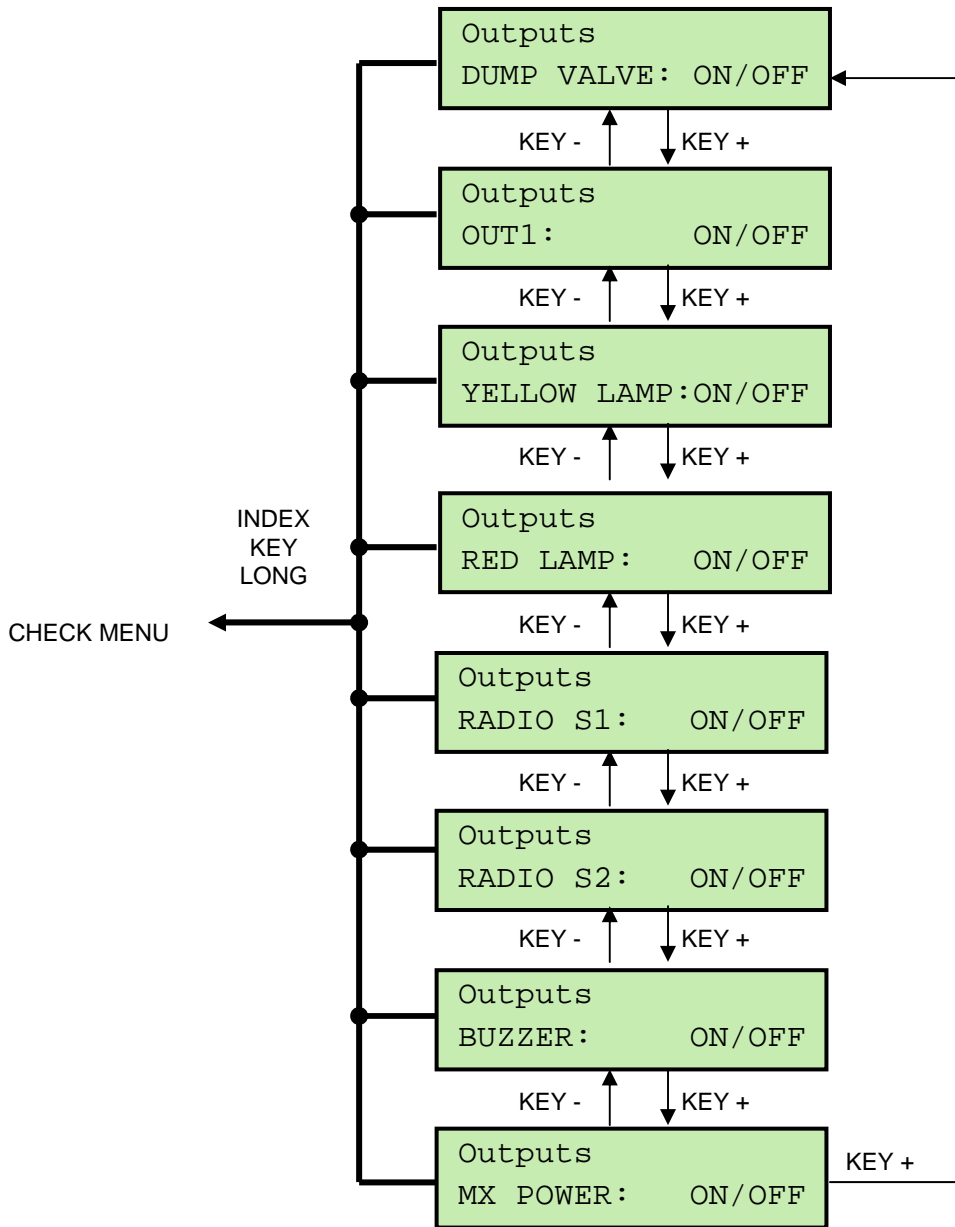

ON = OUTPUT ENABLED  
 OFF = OUTPUT DISABLED

## SENSORS MENU

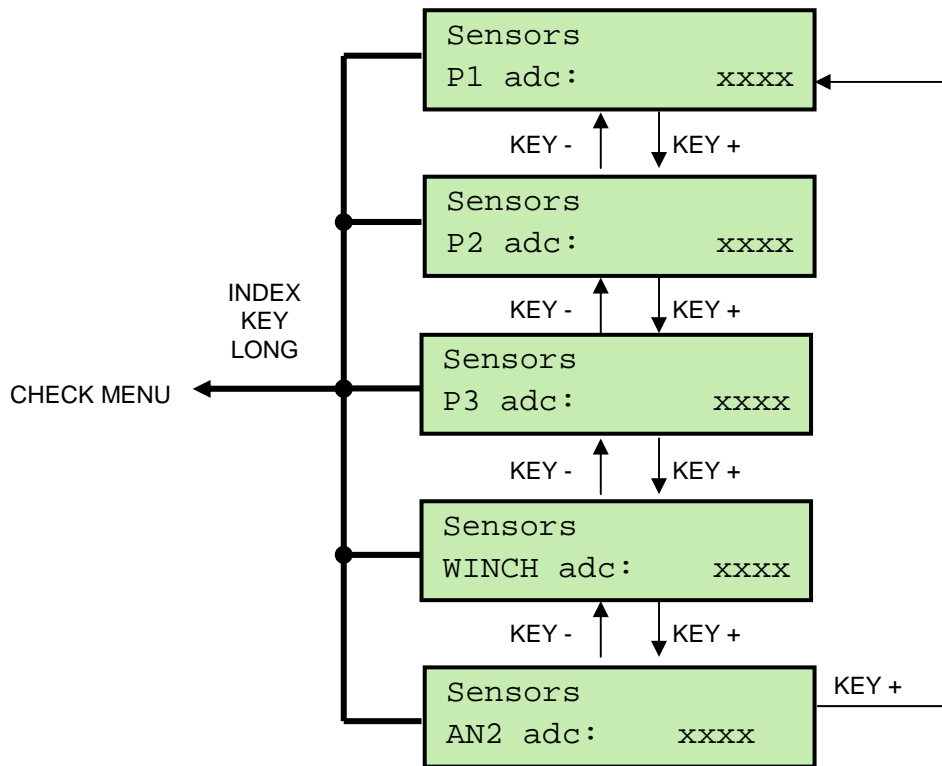

xxxx = value in points read by the sensor  
between 0 and 1023

### ALARM MENU

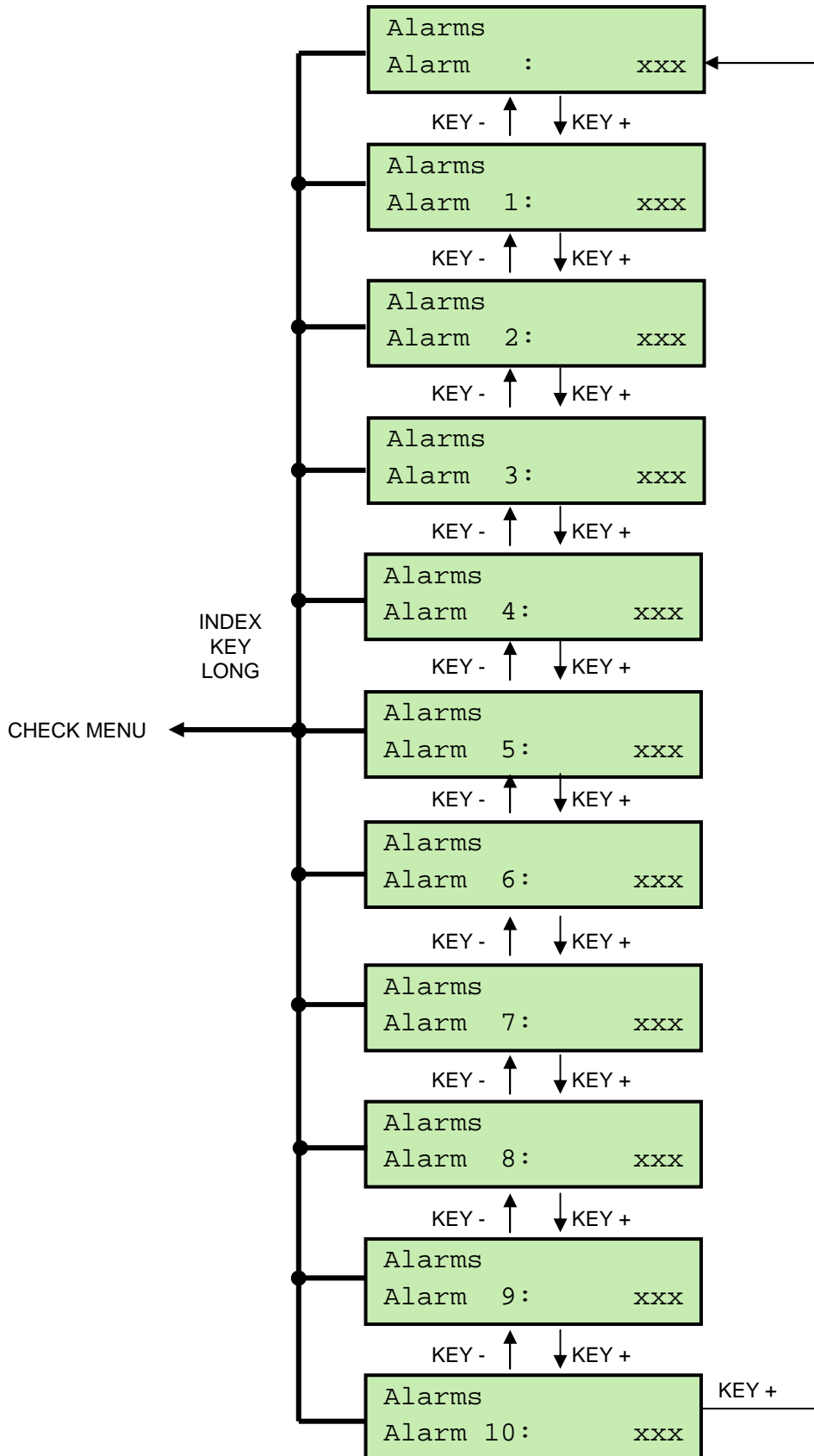

**SERVICE MENU**

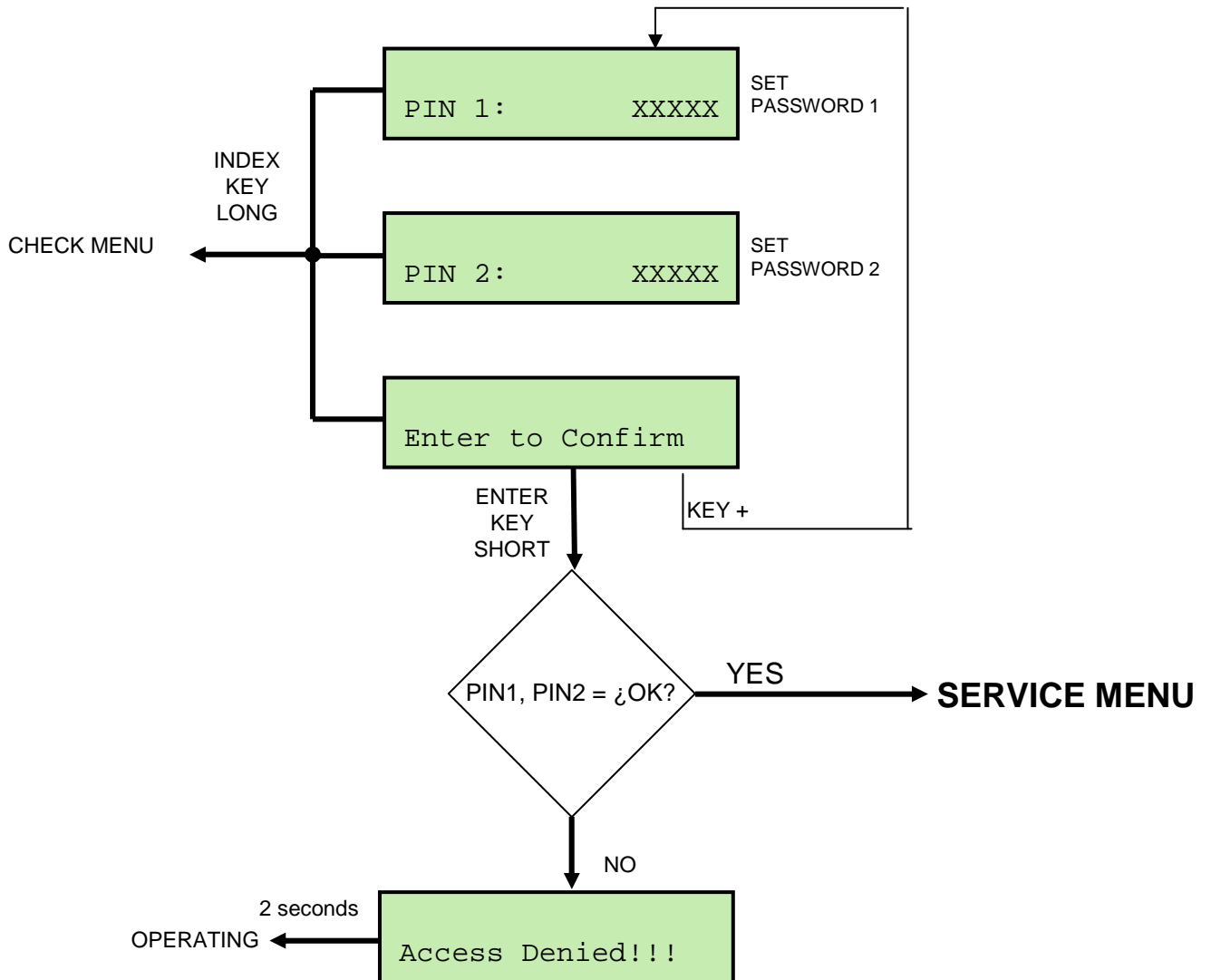

**NOTE:**  
 PIN1 and PIN2 are personal for each installer or authorised technician and should be requested directly to AmcoVeba.  
 Whenever a menu protected by a password is accessed and an operation is carried out, both PIN1 and PIN2 will be saved in the EBB Black Box, so that all modifications and operations carried out on the crane can be tracked.

**SERVICE MENU**

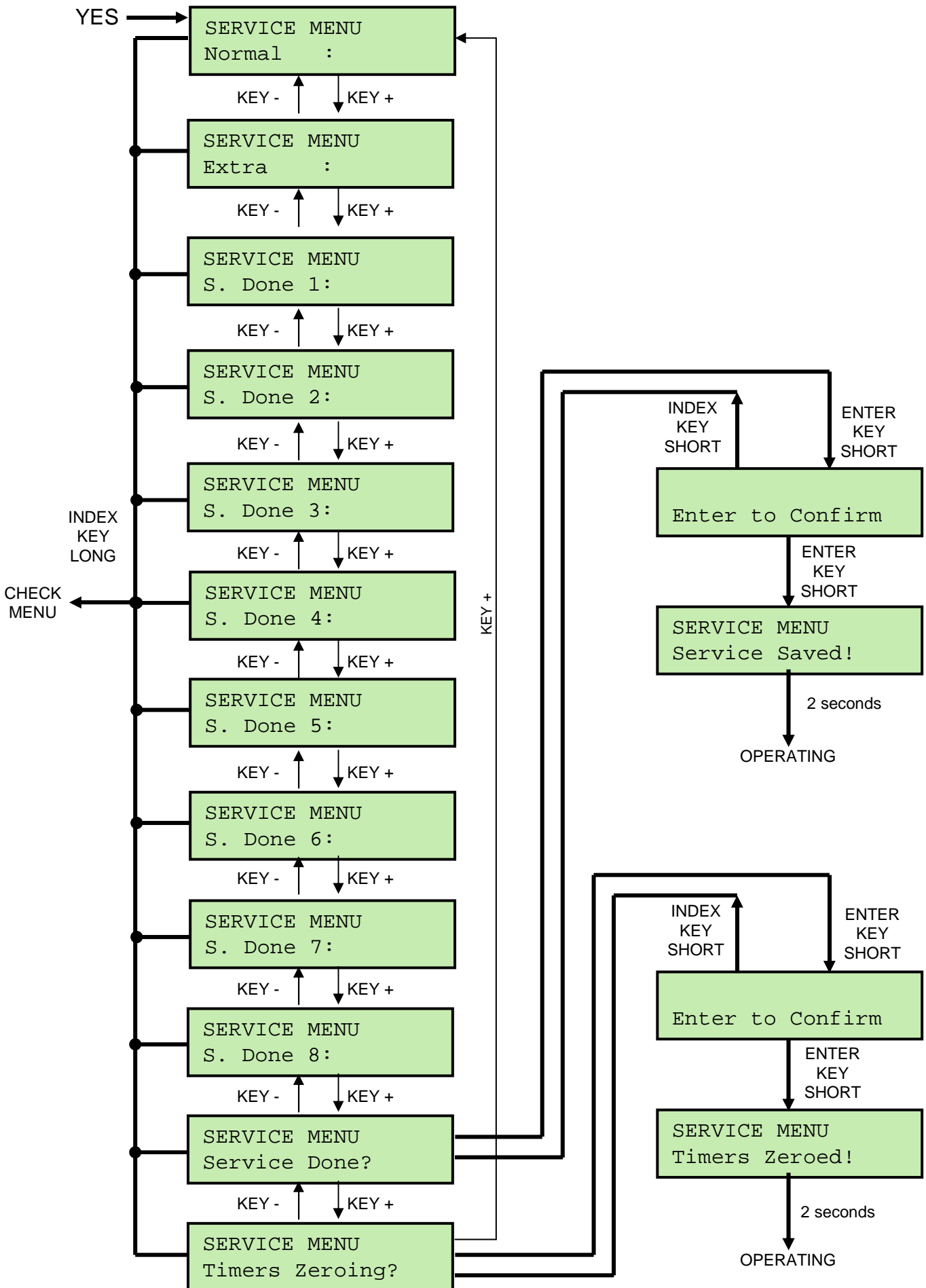

**SETTING MENU - PIN Request**

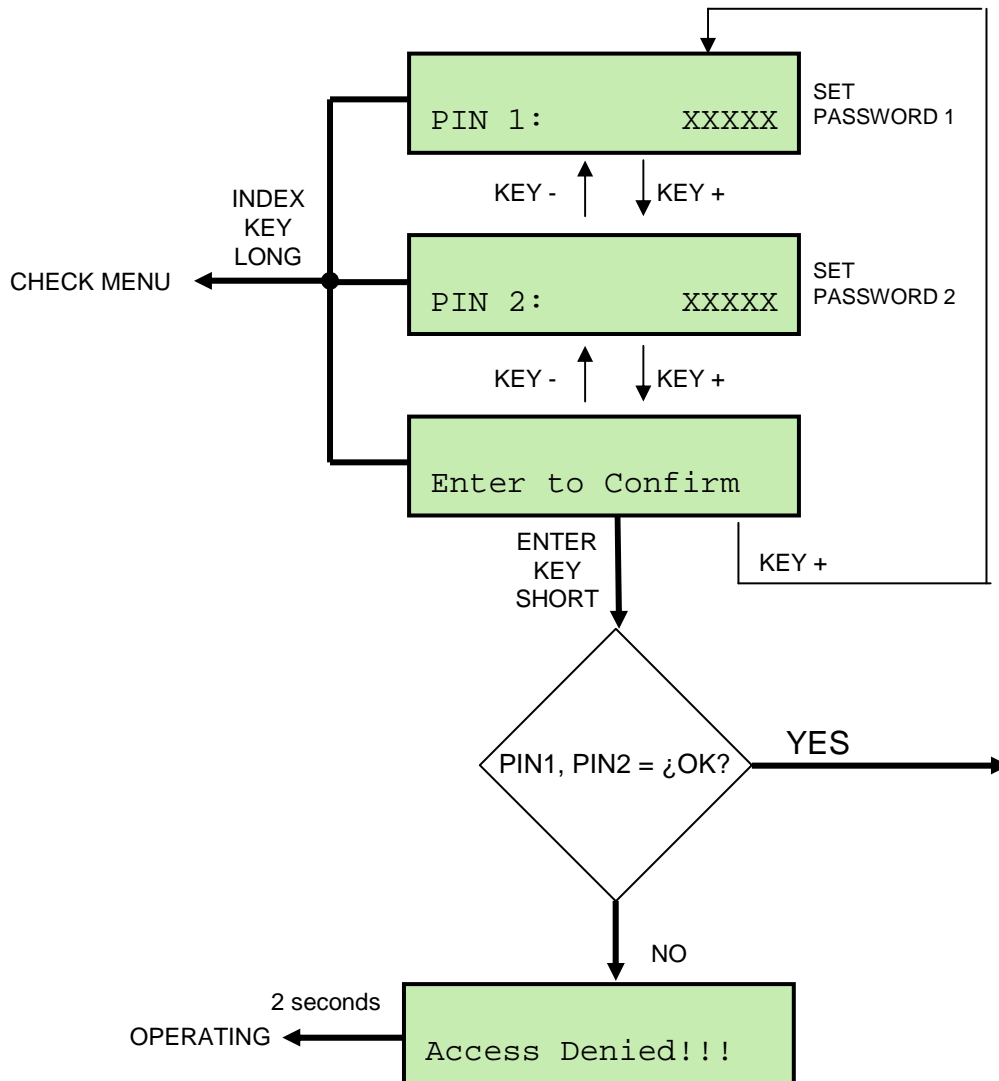

**NOTE:**  
 PIN1 and PIN2 are personal for each installer or authorised technician and should be requested directly to AmcoVeba.  
 Whenever a menu protected by a password is accessed and an operation is carried out, both PIN1 and PIN2 will be saved in the EBB Black Box, so that all modifications and operations carried out on the crane can be tracked.

**SETTING MENU**

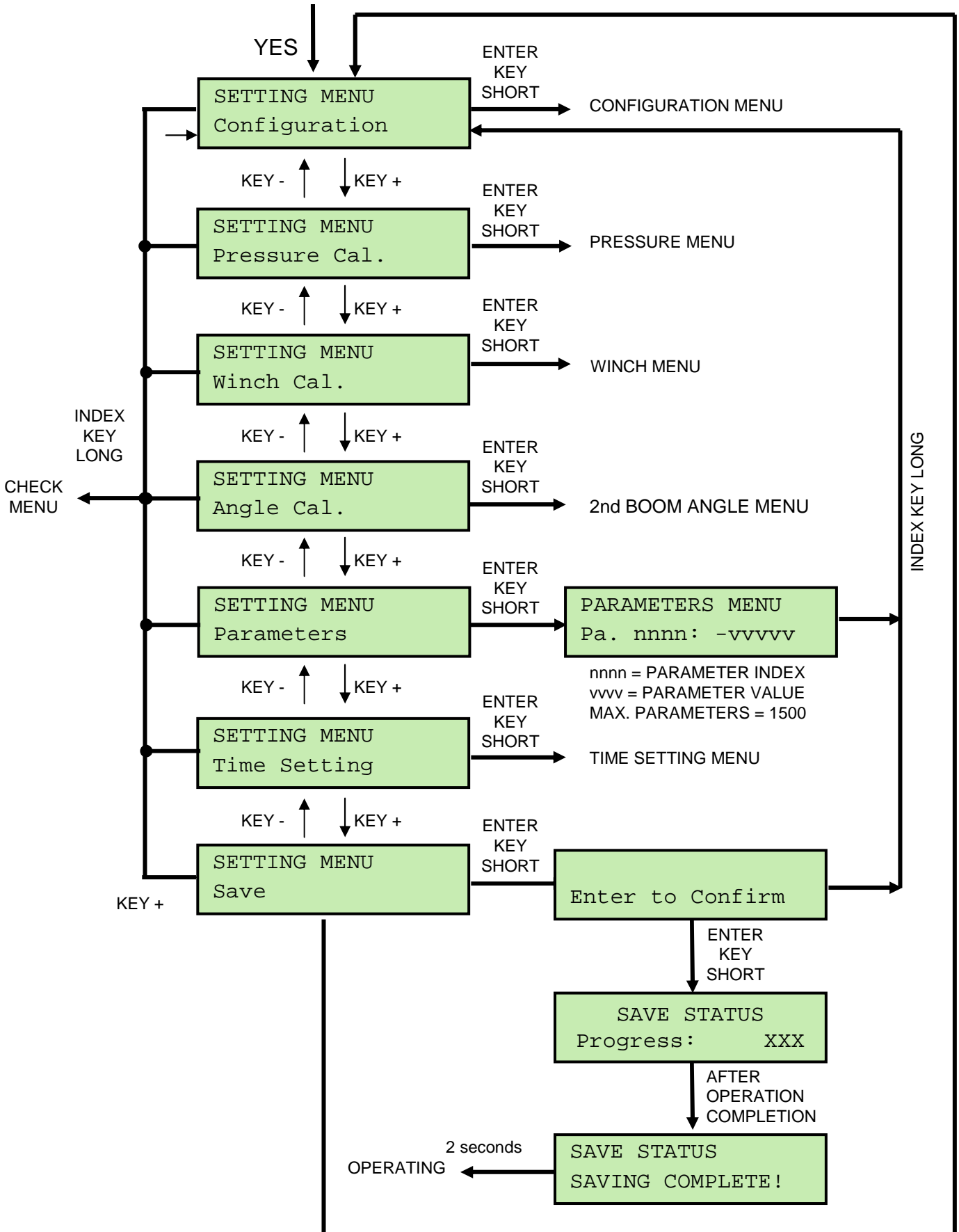

## CONFIGURATION MENU

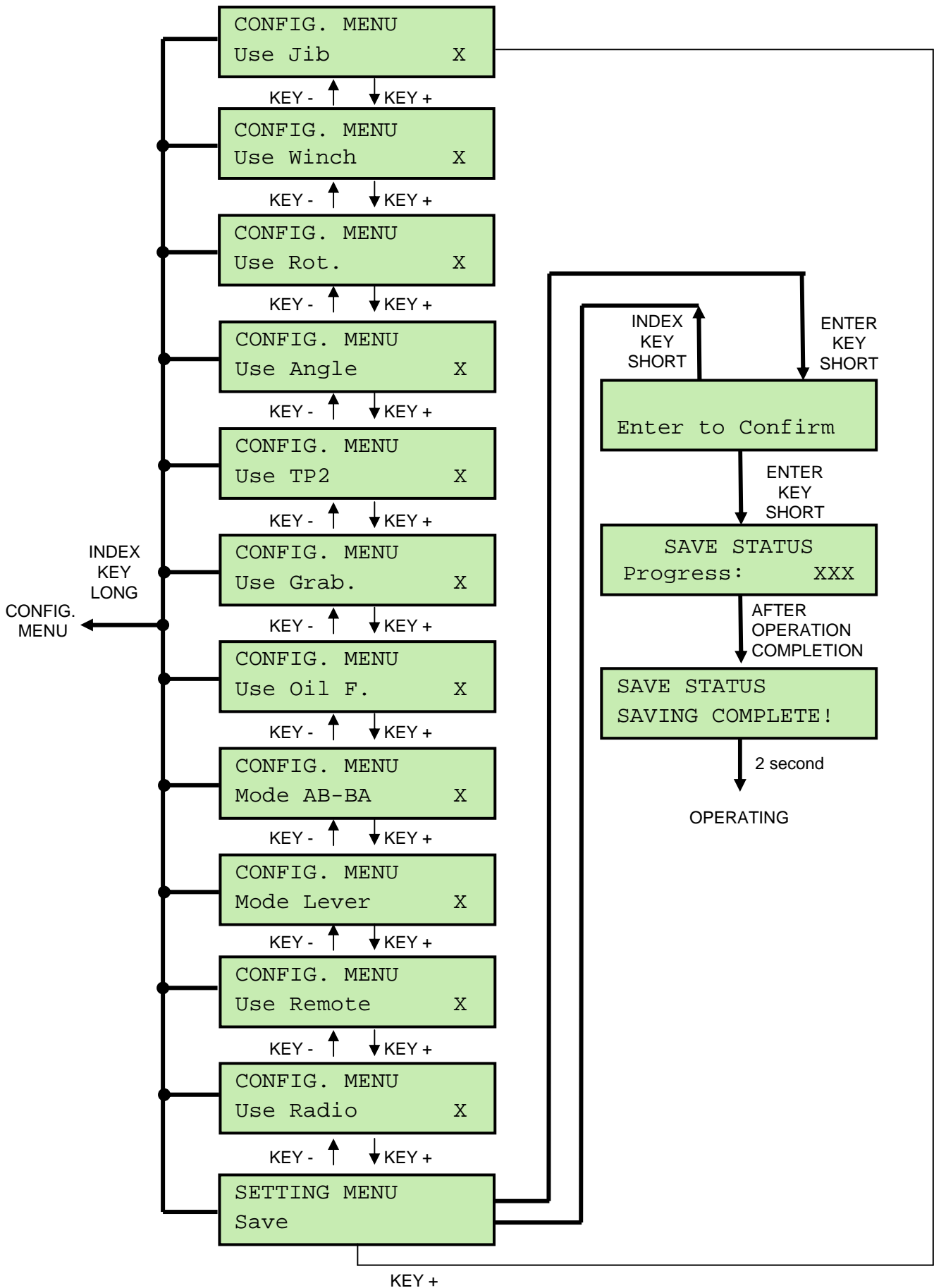

**PRESSURE MENU**

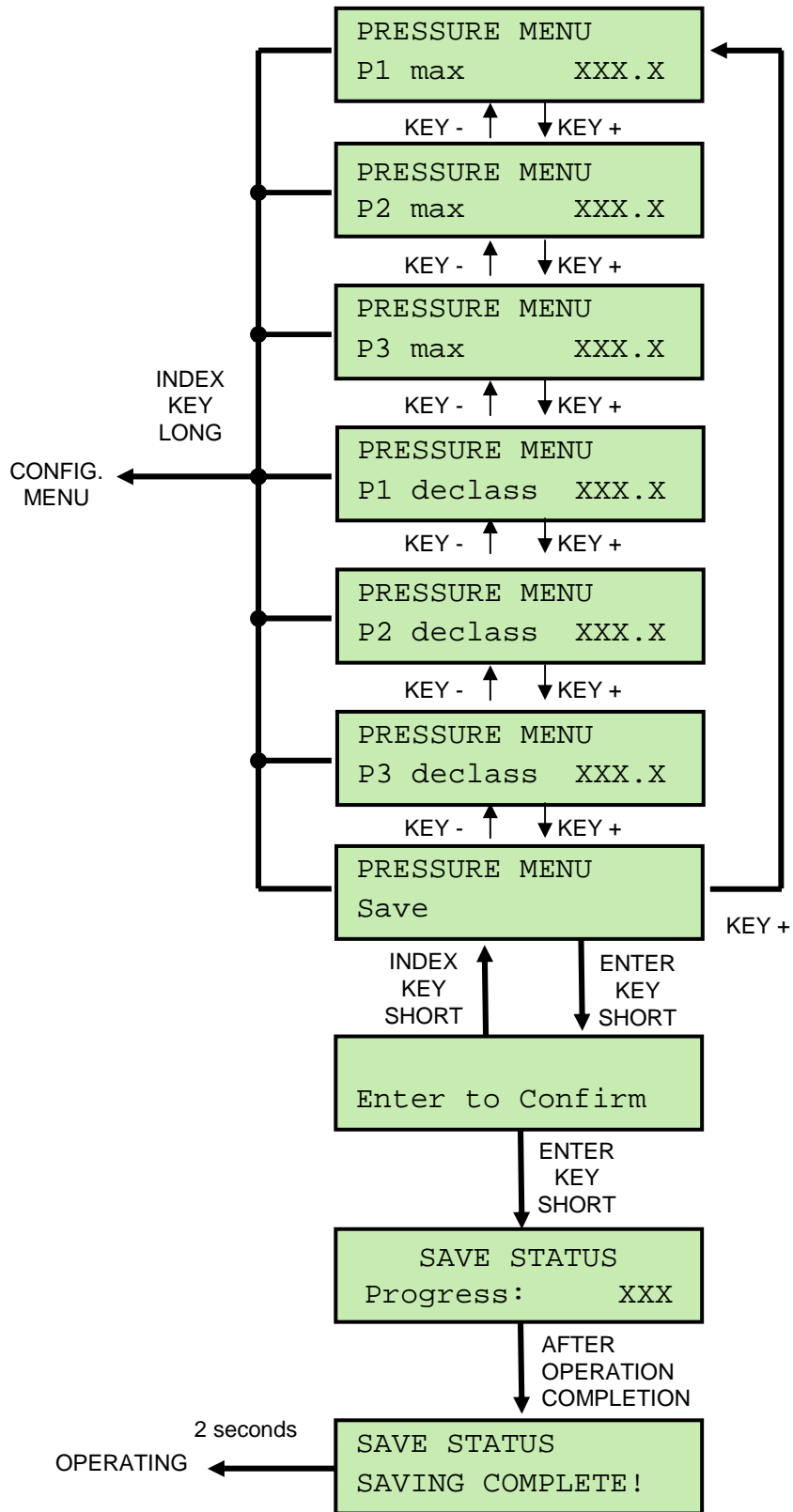

**WINCH MENU**

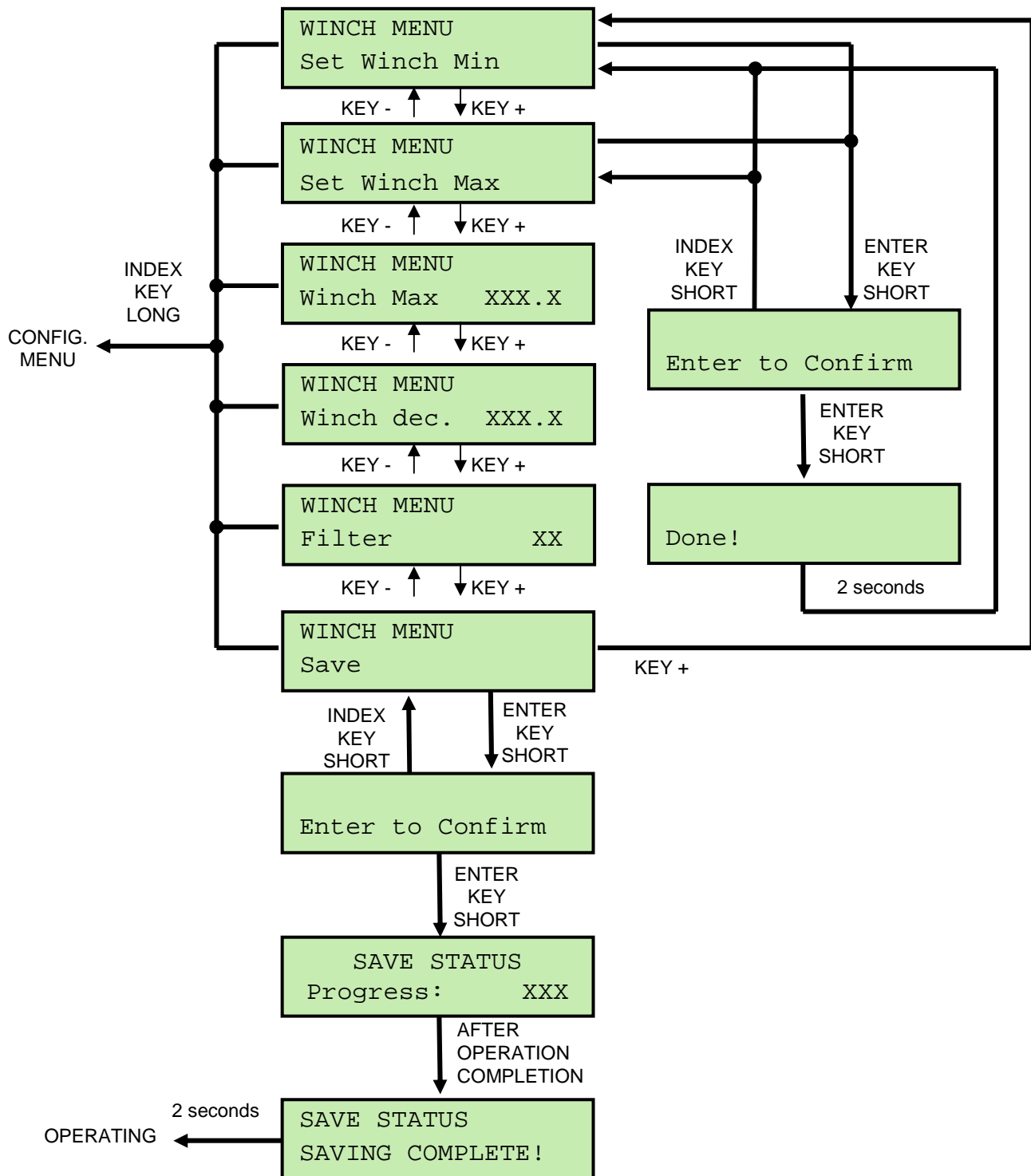

## 2nd BOOM ANGLE MENU

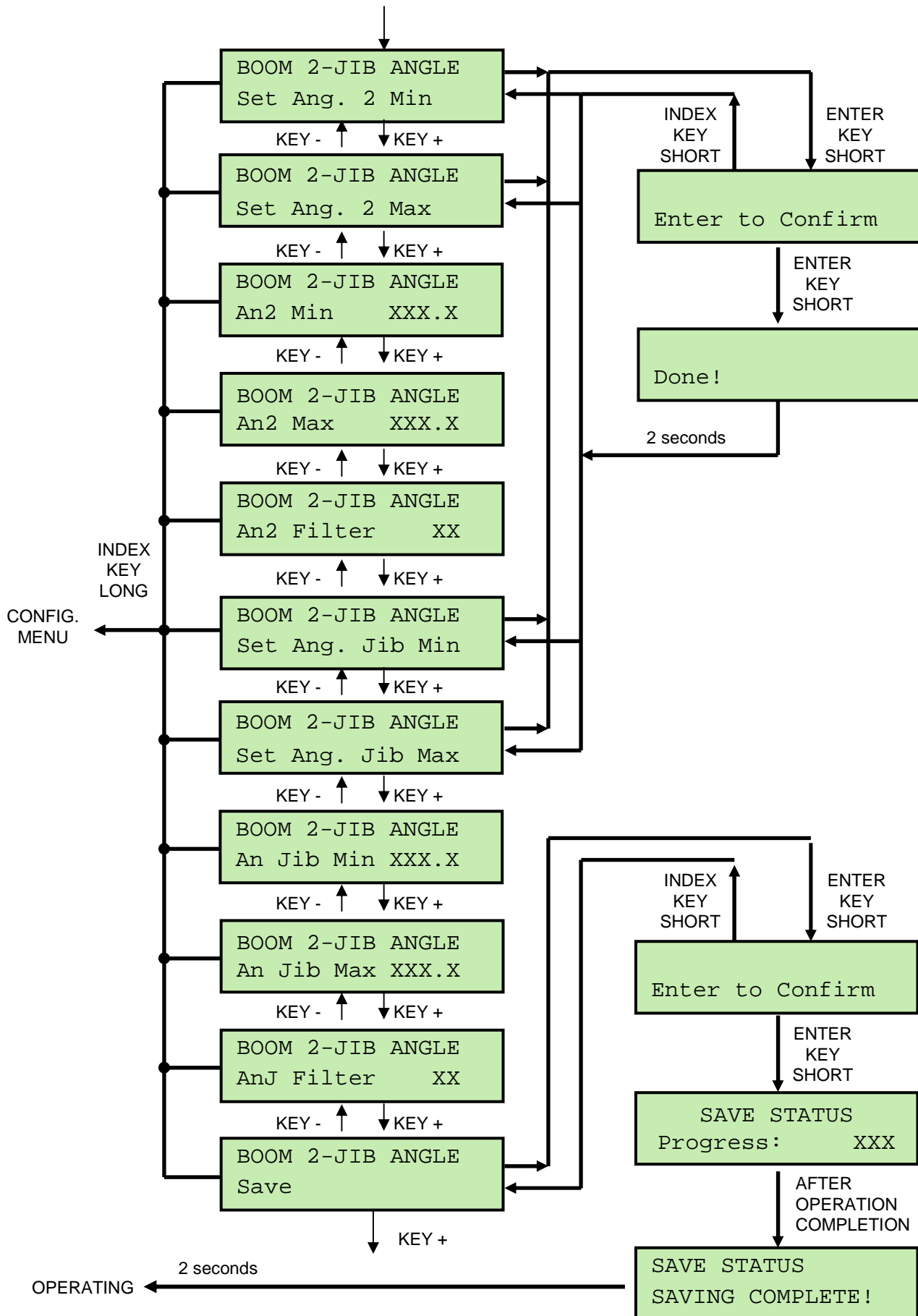

**TIME SETTING**

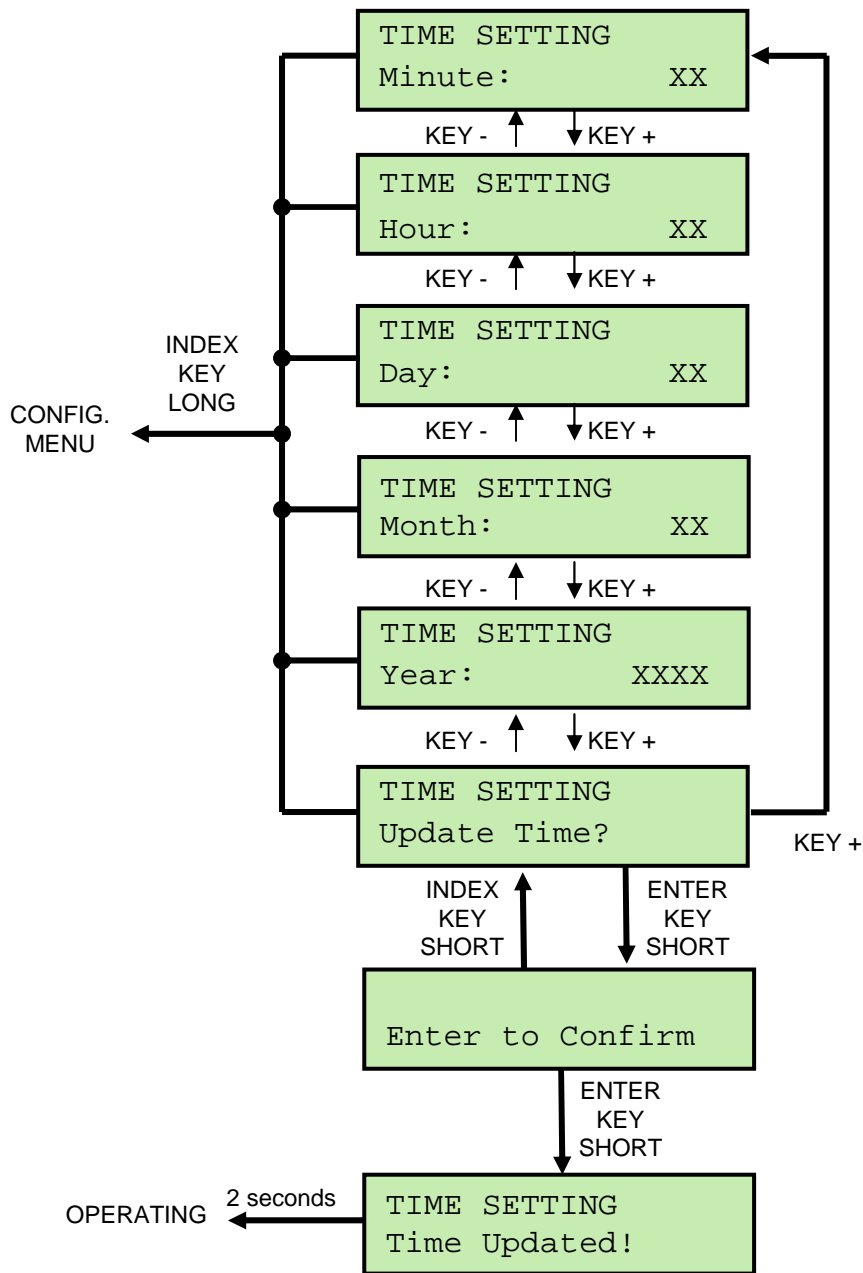

## CALIBRATION

### PARAMETERS LIST AND DESCRIPTION

Parameter Index	Name	Description								
0	paUsaJib	0 = jib not present 1 = jib present								
1	paUsaARG	0 = winch not present 1 = winch present DINAMIC OIL 2 = winch present ROTZLER								
2	paUsaControlloROT	0 = rotation control not present 1 = rotation control present								
3	paUsaBolleAnalogiche	0 = use of ON-OFF bubbles above-below horizon 1 = use of 4-20 mA proportional bubbles								
4	paUsaTP2	0 = TP2 not present 1 = TP2 present								
5	paUsaGrab	0 = equipment not present 1 = equipment present								
6	paUsaFiltriOlio	0 = oil filters not present 1 = oil filters present								
7	paModoDistributore	0 = manoeuvres in the A B direction 1 = manoeuvres in the B A direction								
8	paModoMicro									
		0								
		1								
		2								
		3								
4	4	Ro	B1	B2	S2	W	BJ	SJ	Rotor	Bucket
	0	M1	M2	M3	M4					
	1	M1	M2	M3	M4	M5	M6	M7	M8	
	2	M1	M2	M3	M4	M5	M6	M7		M8
	3	M1	M2	M3	M4	M5			M7	M8
	4	M1	M2	M3	M4		M5	M6	M7	M8
10	paUsaRemoto	0 = remote not present 1 = remote present								
11	paUsaRadio	0 = radio not present 1 = radio present								
12	paUsaStabi	0 = jack arms usage not present 1 = jack arms usage present								
20	DeltaPreSuSbloccoBattuta	maximum pressure increase in bar tenths on jacks limit switch release								
21	TmpSbloccoBattuta	pressure increase control time on jacks limit switch release in tenths of sec.								
22	RADIOsogliaH	high % radio control outputs for slow-down								
23	RADIOsogliaL	low % radio control outputs for slow-down								
25	FILTROSogliaTempo	time, in tenths of sec., after which the crane is stopped for clogged filter								
26	FILTROPsogliaTempo	time, in tenths of sec., after which the crane is stopped for clogged filter								
29	tempoStandByAuto	time in seconds for automatic standby								
30	P1tempoCorrDw	time in tenths of sec. during which the dropping pressure P1 correction is active								
31	P2tempoCorrDw	time in tenths of sec. during which the dropping pressure P2 correction is active								
32	P3tempoCorrDw	time in tenths of sec. during which the dropping pressure P3 correction is active								
35	tempoEvBloccoOn	time in tenths of seconds during which the exhaust valve stays on after a manoeuvre has been interrupted. If set on zero, the valve never activates.								

## PARAMETERS LIST AND DESCRIPTION

Parameter Index	Name	Description
<i>Calibration of limit pressures all in tenths of bar</i>		
40	P1normale	block pressure
41	P1declass	block pressure in downgraded area
42	P1nominale	maximum settable block pressure
43	P1deltaUsoRadio	Increase in block pressure with radio control ON
44	P1deltaUsoAttrezzi	Reduction of limit pressure with equipment enabled
45	P2normale	block pressure
46	P2declass	block pressure in downgraded area
47	P2nominale	maximum settable block pressure
50	P3normale	block pressure
51	P3declass	block pressure in downgraded area
52	P3nominale	maximum settable block pressure
<i>Limit values setting for winch pull limiting device</i>		
60	ARGnormale	maximum pull
61	ARGdeclass	maximum pull in unstable area
62	ARGnominale	maximum settable pull
65	ARGang1	winch pull reduction start angle (e.g. 450 = 45°)
66	ARGmax1	reduction rate related to angle 1 (e.g. 100)
67	ARGang2	reduction end angle (e.g. 800 = 80°)
68	ARGmax2	reduction rate related to angle 2 (e.g. 50)
70	---	System parameter for Winch limiting device management
75	ARGJang1	winch pull reduction start Jib angle (e.g. 450 = 45°)
76	ARGJmax1	reduction rate related to angle 1 of the Jib (e.g. 100)
77	ARGJang2	reduction end Jib angle (e.g. 800 = 80°)
78	ARGJmax2	reduction rate related to angle 2 of the Jib (e.g. 50)
<i>Setting the winch pull increase limiting device</i>		
80	ARGusaBloccoDelta	0 = increase control OFF; 1 = increase control ON
81	ARGnFiltroBelta	Pull value filter constant only for increase control
82	ARGsogliaVuotoCarico	It shows the pull threshold to identify loaded or unloaded winch – range 0 - 1000
83	ARGmaxDeltaVuoto	maximum pull delta below the empty-loaded threshold (when empty)
84	ARGmaxDeltaCarico	maximum pull delta above the empty-loaded threshold (when loaded)
<i>Setting the time for limiting device disabling activation</i>		
100	EBtempoTastoManovra	time in tenths of sec. after pressing the reset key during which a manoeuvre can be started
101	EBtempoAbiManovra	manoeuvre maximum allowed time in tenths of seconds
102	EBtempoRipeteManovra	time in tenths of sec. after which the manoeuvre can be repeated
<i>Setting the hours for scheduled maintenance operations</i>		
120	SERVore1	first maintenance time in hours
121	SERVore2	second maintenance time in hours
122	SERVore3	third maintenance time in hours
123	SERVore4	fourth maintenance time in hours
124	SERVoreSucc	time in hours between subsequent maintenance operations

## PARAMETERS LIST AND DESCRIPTION

Parameter Index	Name	Description
<i>Calibration of 4-20 mA 400 bar transducers. The same for the three pressure transducers</i>		
200	P1adc1	164
201	P1noto1	0 = 0 bar
202	P1adc2	819
203	P1noto2	4000 = 400 bar
204	P1nFiltro	20 mobile average (max 30) filter samples
<i>Dropping pressure correction calibration in tenths of bar, values are linearly interpolated</i>		
210	P1dwPres1	pressure 1 dropping
211	P1dwCorr1	pressure 1 correction
212	P1dwPres2	pressure 2 dropping
213	P1dwCorr2	pressure 2 correction
215	P1upPres1	pressure 1 increasing
216	P1upCorr1	pressure 1 correction
217	P1upPres2	pressure 2 increasing
218	P1upCorr2	pressure 2 correction
219	P1tempoCorrUp	time in tenths of seconds during which the pressure P1 increasing correction stays on
220	P2adc1	164
221	P2noto1	0 = 0 bar
222	P2adc2	819
223	P2noto2	4000 = 400 bar
224	P2nFiltro	20 mobile average (max 30) filter samples
230	P2dwPres1	pressure 1 dropping
231	P2dwCorr1	pressure 1 correction
232	P2dwPres2	pressure 2 dropping
233	P2dwCorr2	pressure 2 correction
235	P2upPres1	pressure 1 increasing
236	P2upCorr1	pressure 1 correction
237	P2upPres2	pressure 2 increasing
238	P2upCorr2	pressure 2 correction
239	P2tempoCorrUp	time in tenths of seconds during which the pressure P1 increasing correction stays on
240	P3adc1	164
241	P3noto1	0 = 0 bar
242	P3adc2	819
243	P3noto2	4000 = 400 bar
244	P3nFiltro	20 mobile average (max 30) filter samples
250	P3dwPres1	pressure 1 dropping
251	P3dwCorr1	pressure 1 correction
252	P3dwPres2	pressure 2 dropping
253	P3dwCorr2	pressure 2 correction
255	P3upPres1	pressure 1 increasing
256	P3upCorr1	pressure 1 correction
257	P3upPres2	pressure 2 increasing
258	P3upCorr2	pressure 2 correction
259	P3tempoCorrUp	time in tenths of seconds during which the pressure P1 increasing correction stays on

## PARAMETERS LIST AND DESCRIPTION

Parameter Index	Name	Description
<i>Calibration of extensometer on winch</i>		
260	ARGadc1	zero ANALOGUE reading
261	ARGnoto1	0 = 0 %
262	ARGadc2	ANALOGUE reading at maximum pull
263	ARGnoto2	1000 = 100 %
264	ARGnFiltro	number of samples for the filter
<i>Calibration of secondary boom angular sensor</i>		
280	AN2adc1	ANALOGUE reading in known point 1
281	AN2noto1	real angular value of point 1 in tenths of degree
282	AN2adc2	ANALOGUE reading in known point 2
283	AN2noto2	real angular value of point 2 in tenths of degree
284	AN2nFiltro	number of samples for the filter
<i>Calibration of Jib angular sensor</i>		
290	ANJadc1	ANALOGUE reading in known point 1
291	ANJnoto1	real angular value of point 1 in tenths of degree
292	ANJadc2	ANALOGUE reading in known point 2
293	ANJnoto2	real angular value of point 2 in tenths of degree
294	ANJnFiltro	number of samples for the filter

## BASIC CALIBRATION FROM PANEL

The calibration of limit pressures, of the winch pull limiting device, of the secondary boom proportional angular sensor, and the setting of main parameters are grouped in dedicated menus

### Limit Pressures Calibration..

P1 max	maximum pressure of primary jack in stable area
P2 max	maximum pressure of secondary jack in stable area
P3 max	maximum pressure of Jib jack in stable area
P1 declass	maximum pressure of primary jack in unstable area
P2 declass	maximum pressure of secondary jack in unstable area
P3 declass	maximum pressure of Jib jack in unstable area

### Winch pull Limiting Device Calibration.

Set Winch Min	zero setting of load sensor (no hooked load)
Set Winch Max	setting of 100% of the load sensor (maximum load hooked)
Winch max	maximum pull in stable area (percentage)
Winch dec.	maximum pull in unstable area (percentage)
Filter	load sensor filtering (range 0-30)

### 2nd Boom Proportional Angular Sensor Calibration

Set Ang. 2 Min	setting of sensor minimum angle (boom in horizontal position)
Set Ang. 2 Max	setting of sensor maximum angle (boom completely up)
An2 Min	Real minimum angle in tenths of degree (boom in horizontal position)
An2 Max.	Real maximum angle in tenths of degree (boom completely up)

### Jib Proportional Angular Sensor Calibration

Set Ang. Jib Min	setting of sensor minimum angle (boom in horizontal position)
Set Ang. Jib Max	setting of sensor maximum angle (boom completely up)
An Jib Min	Real minimum angle in tenths of degree (boom in horizontal position)
An Jib Max.	Real maximum angle in tenths of degree (boom completely up)
AnJ Filter	angle sensor filtering (range 0-30)

### Crane Setting

Use Jib	0 = Jib not present; 1 = Jib present
Use Winch	0 = Winch not present; 1 = Winch present (DINAMIC OIL); 2 = Winch present (ROTZLER)
Use Rot.	0 = Rotation control not present; 1 = Rotation control present
Use Angle2	0 = 2 <sup>nd</sup> boom Angular Sensor not present; 1 = 2 <sup>nd</sup> boom Angular Sensor present
Use TP2	0 = 2 <sup>nd</sup> boom pressure transducer not present; 1 = 2 <sup>nd</sup> boom pressure transducer present;
Use Grab	0 = Equipment not present; 1 = Equipment present
Use Oil F.	0 = Oil filters not present; 1 = Oil filters present
Mode AB-BA	0= Levers direction AB; 1 = Levers direction BA
Mode Lever	Manipulators configuration (reference parameter No. 8)
Use Remote	0 = Remote Panel not present; 1 = Remote Panel present
Use Radio	0 = Crane without radio control; 1 = Crane with radio control

## DIAGNOSTICS

List of UAV Limiting Device Input		
	Name	Description
1	M1A	It indicates the movement of the first lever of the Distributor in direction A
2	M1A	It indicates the movement of the first lever of the Distributor in direction B
3	M2A	It indicates the movement of the second lever of the Distributor in direction A
4	M2A	It indicates the movement of the second lever of the Distributor in direction B
5	M3A	It indicates the movement of the third lever of the Distributor in direction A
6	M3A	It indicates the movement of the third lever of the Distributor in direction B
7	M4A	It indicates the movement of the fourth lever of the Distributor in direction A
8	M4A	It indicates the movement of the fourth lever of the Distributor in direction B
9	M5A	It indicates the movement of the fifth lever of the Distributor in direction A
10	M5A	It indicates the movement of the fifth lever of the Distributor in direction B
11	M6A	It indicates the movement of the sixth lever of the Distributor in direction A
12	M6A	It indicates the movement of the sixth lever of the Distributor in direction B
13	M7A	It indicates the movement of the seventh lever of the Distributor in direction A
14	M7A	It indicates the movement of the seventh lever of the Distributor in direction B
15	M8A	It indicates the movement of the eighth lever of the Distributor in direction A
16	M8A	It indicates the movement of the eighth lever of the Distributor in direction B
17	B2 UP ORIZ	Second Boom above horizontal level
18	B2 DW ORIZ	Second Boom below horizontal level
19	JIB UP ORIZ	Jib below horizontal level
20	JIB DW ORIZ	Jib Boom below horizontal level
21	FC ROT DX	Clockwise rotation limit switch
22	FC ROT SX	Anti-clockwise rotation limit switch
23	FC WINCH UP	Winch ascent limit switch
24	FC WINCH DW	Winch descent limit switch
25	RADIO RESET	RESET key on Radio control
26	RADIO EV	Activation consensus from Radio control
27	Inp OUT0	Output 0 rereading input
28	Inp OUT1	Output 1 rereading input
29	Inp CR1	Contact relay 1 on pin 43 rereading input
30	Inp CR2	Contact relay 2 on pin 16 rereading input
31	Inp VP	Outputs supply on pin 28 rereading input

## DIAGNOSTIC

List of UAV Limiting Device Outputs		
	Name	Description
1	DUMP VALVE	Output for oil drain solenoid due to machine stop
2	OUT 1	Not used
3	YELLOW LAMP	Output for yellow lamp
4	RED LAMP	Output for red lamp
5	RADIO S1	Output for movement slow-down from radio control threshold 1
6	RADIO S2	Output for movement slow-down from radio control threshold 2
7	BUZZER	Output for horn activation
8	Mxy Power	Output for supply of micro switches on distributor

List of Inputs from UAV Limiting Device Sensors		
	Name	Description
1	P1 adc	Input for primary boom pressure transducer reading
2	P2 adc	Input for secondary boom pressure transducer reading
3	P3 adc	Input for Jib pressure transducer reading
4	WINCH adc	Input for winch load sensor reading
5	AN2 adc	Input for proportional angular sensor reading on second boom
6	ANJ adc	Input for proportional angular sensor reading on Jib

## LIST OF ALARMS

The following table shows all the alarm codes blocking the machine, the related possible verifications, and the potential solutions.

The **ALARMS BYPASS** procedure can always be followed

Alarm number	Description	Possible cause	Solution
1	Saved parameters corrupted	Battery voltage drop during switch-on EBB failure	Re-load the original calibration and save Replace EBB
4	Power supply not present on PIN 43	Main fuse faulty Interrupted or damaged cable	Check fuse Check wiring
5	Faulty block output on	Short circuit on the cable Short circuit on the general valve coil EBB output faulty	Check wiring Check connectors Replace general valve coil Replace EBB
6	Faulty block output off		
7	Open or positive faulty watch-dog relay present on pin 43 but not on pin 15 after relay activation	Short circuit on emergency wiring Internal relay faulty	Check wiring Check emergency knobs connections Replace emergency knob Replace EBB
8	Close or positive faulty watch-dog relay present on pin even after commanding relay opening.		
9	Positive not present on pin 43 but present on pin 15		
10	TP1 reading too low (open circuit)	Interrupted cable Short circuit on the cable Power supply failure Damaged connectors Faulty component	Check connection Check power supply presence on connector Replace connector Replace component
11	TP1 reading too high (short circuit)		
20	TP2 reading too low (open circuit)		
21	TP2 reading too high (short circuit)		
30	TP3 reading too low (open circuit)		
31	TP3 reading too high (short circuit)		
40	reading from extensometer amplifier too low (open circuit)		
41	reading from extensometer amplifier too high (short circuit)		
42	both hoist limit switches are enabled		
50	B2 bubble inputs both OFF		
51	B2 bubble inputs both ON		
52	JIB bubble inputs both OFF		
53	JIB bubble inputs both ON		
54	AN2 reading too low (open circuit)		
55	AN2 reading too high (short circuit)		
56	ANJ reading too low (open circuit)		
57	ANJ reading too high (short circuit)		

### LIST OF ALARMS

Alarm number	Description	Possible cause	Solution
60	both rotation micro switches OFF	Interrupted cable Short circuit on the cable Power supply failure Damaged connectors Faulty micro switch	Check connection Check power supply presence on connector Replace connector Replace component
61	both primary boom micro switches OFF		
62	both secondary boom micro switches OFF		
63	both crane extension boom micro switches OFF		
64	both jib boom micro switches OFF		
65	both jib extension boom micro switches OFF		
66	both winch micro switches OFF		
67	both bucket micro switches OFF		
68	both rotor micro switches OFF		

## LIST OF WARNINGS

The following table includes all possible 'Warning' codes.

Unlike the alarms, 'Warnings' do not block the machine, but simply highlight a malfunctioning.

If the malfunctioning is solved, everything is reset automatically.

Warning umber	Description	Possible cause	Solution
1	The main panel does not receive the CAN BUS message from the remote panel	Interrupted cable Damaged cable or connectors Faulty remote panel	Check connection Check connectors Check for remote panel integrity
2	The remote panel does not receive the CAN BUS message from the main panel	Faulty EBB	Replace remote panel Replace EBB

## PROBLEM SOLVING

The following table includes some possible failures or malfunctioning situations, their possible causes, and the potential solutions. .

Defect	Possible Cause	Solution
The crane does not move, the EBB is off	EBB not energised	Check EBB power supply circuit
The crane does not move, the EBB is on with normal operating signals	General valve enabling signal missing General valve coil faulty Connection to the general valve faulty General valve faulty During RADIO operation, the enabling signal on pin 14 is not received EBB output faulty	Check connection (s) Replace general valve coil Replace general valve Check connection with the RADIO Check for presence of signal coming from the radio Replace the RADIO Replace EBB
The crane does not move, the EBB is on and an alarm is shown on the display	Refer to List of Alarms	Refer to List of Alarms

## List of EBB sheet resources

56 Pole Connector						
No.	Name	Function	Voltage	Current	Notes	Connection
1	RX232	PROG. SERIAL RX				
2	TX232	PROG. SERIAL TX				
3	CA1	ANALOGUE CHANNEL 1			FIXED	
4	CA3	ANALOGUE CHANNEL 3			FIXED	
5	CA9	ANALOGUE CHANNEL 9			SETTABLE FROM SW WITH MOS4	
6	CA11	ANALOGUE CHANNEL 11			SETTABLE FROM SW WITH MOS4	
7	CA5	ANALOGUE CHANNEL 5	0 – 5.5 Volts		SETTABLE FROM SW WITH MOS1	
8	CA7	ANALOGUE CHANNEL 7	0 – 5.5 Volts		SETTABLE FROM SW WITH MOS1	
9	CA13	ANALOGUE CHANNEL 13	0 – 30 Volts/ 0 – 5.5 Volts		SETTABLE FROM SW WITH MOS3	RIGHT ROT. L.S.
10	CA15	ANALOGUE CHANNEL 15	0 – 30 Volts/ 0 – 5.5 Volts		SETTABLE FROM SW WITH MOS3	
11	AGND	ANALOGUE EARTH		MAX 0.5A		NEG SENSORS
12	INP18	DIGITAL INPUT 18			WITH PULL UP FROM SW	
13	INP16	DIGITAL INPUT 16			WITH PULL UP FROM SW	OIL FILTER S
14	INP19	DIGITAL INPUT 19			WITH PULL UP FROM SW	
15	CR2	CONTACT 2 RELAY WDO				TO EM. KNOB
16	INP1	DIGITAL INPUT 1				
17	INP3	DIGITAL INPUT 3				
18	INP5	DIGITAL INPUT 5				
19	INP7	DIGITAL INPUT 7				
20	INP9	DIGITAL INPUT 9				
21	INP11	DIGITAL INPUT 11				
22	INP13	DIGITAL INPUT 13				
23	OUT0	DIGITAL OUTPUT/PWM 0				BLOCK EV
24	OUT2	DIGITAL OUTPUT/PWM 2				YELLOW LAMP
25	OUT4	DIGITAL OUTPUT/PWM 4				
26	OUT6	DIGITAL OUTPUT/PWM 6				EXTERNAL BUZZER
27	OUT7	DIGITAL OUTPUT/PWM 7				Mxy Pw supply
28	VPE	OUTPUT POWER SUPPLY				FROM EM. KNOB
39	CAN1L	CAN BU LINE LOW				
30	CAN1H	CAN BUS LINE HIGH				
31	CA0	ANALOGUE CHANNEL 0			FIXED	
32	CA2	ANALOGUE CHANNEL 2			FIXED	
33	CA8	ANALOGUE CHANNEL 8			SETTABLE FROM SW WITH MOS2	
34	CA10	ANALOGUE CHANNEL 10			SETTABLE FROM SW WITH MOS2	
35	CA4	ANALOGUE CHANNEL 4	0-5-5- Volts		SETTABLE FROM SW WITH MOS1	ADC WINCH PULL
36	CA6	ANALOGUE CHANNEL 6	0-5-5- Volts		SETTABLE FROM SW WITH MOS1	
37	CA12	ANALOGUE CHANNEL 12	0 – 30 Volts/ 0 – 5.5 Volts		SETTABLE FROM SW WITH MOS3	LEFT ROTAT L.S.
38	CA14	ANALOGUE CHANNEL 14	0 – 30 Volts/ 0 – 5.5 Volts		SETTABLE FROM SW WITH MOS3	WINCH STOP IN
39	DGND	DIGITAL EARTH		MAX 0.5 A		
40	15V	REF. +15V				TP PW SUPPL
41	INP17	DIGITAL INPUT 17			WITH PULL UP FROM SW	OIL FILTER P
42	INP15	DIGITAL INPUT 15				
43	CR1	CONTACT 2 RELAY WDO				
44	INP0	DIGITAL INPUT 0				
45	INP2	DIGITAL INPUT 2				
46	INP4	DIGITAL INPUT 4				
47	INP6	DIGITAL INPUT 6				
48	INP8	DIGITAL INPUT 8				
49	INP10	DIGITAL INPUT 10				
50	INP12	DIGITAL INPUT 12				
51	INP14	DIGITAL INPUT 14				
52	OUT1	DIGITAL OUPUT / PWM 1				
53	OUT3	DIGITAL OUPUT / PWM 3				RED LAMP
54	OUT5	DIGITAL OUPUT / PWM 5				
55	-VB	PW SUPPL NEGATIVE		MAX 2.5A		PW SUPPL FROM -VB
56	+VB	PW SUPPL POSITIVE		MAX 2.5A		PW SUPPLY FROM +VB